



Microscience Manual
Physics Teachers' Manual

**Second Guyana Version Adaptation of Teaching and Learning
Materials on Microscience Experiments**



United Nations
Educational, Scientific and
Cultural Organization

**Funded by UNESCO in collaboration with the Ministry of Education and the University of
Guyana**

Updated on: April 10, 2015

Contents

Participants	2
A Message from the Minister of Education	3
Introduction to the first Guyana version adaptation of UNESCO teaching and learning materials on micro science experiments	4
EXPERIMENT 1 – GET TO KNOW YOUR MICRO-ELECTRICITY KIT.....	5
EXPERIMENT 2 – LIGHTEN UP, PREDICT AND EXPLORE.....	7
EXPERIMENT 3 –CAR HEADLIGHTS	8
EXPERIMENT 4 – MAKING AN ELECTRIC CURRENT DETECTOR.....	10
EXPERIMENT 5 – THE CURRENT IN A SERIES CIRCUIT.....	11
EXPERIMENT 6 – LIGHT BULBS IN SERIES.....	12
EXPERIMENT 7 – LIGHT BULBS IN PARALLEL.....	13
EXPERIMENT 8 – ONE AFTER THE OTHER, CAUSING A GREAT BOTHER	14
EXPERIMENT 9 – FREE ELECTRONS ARE NOT SO FREE!	17
EXPERIMENT 10 – WHAT GOES UP MUST FALL DOWN.....	21
EXPERIMENT 11 – THE CURRENT IN A SERIES CIRCUIT.....	23
EXPERIMENT 12 – THE REAL & THE IDEAL WORLD.....	24
EXPERIMENT 13 – THE INVESTIGATION	27
EXPERIMENT 14 – POTENTIAL DIFFERENCE ACROSS POINTS IN A SERIES CIRCUIT	29
EXPERIMENT 16 – OHM’S LAW.....	32
EXPERIMENT 17 – SOLENOIDS & ELECTROMAGNETS.....	34
EXPERIMENT 18 – FEDERAL BUREAU of INVESTIGATIONS, FBI	36
EXPERIMENT 19 – COMING ATTRACTION.....	38
EXPERIMENT 20 – FIELDING.....	40
EXPERIMENT 21 – THE STRONGEST OF THEM ALL!	42
EXPERIMENT 22 – AMMETER, TO BE AND NOT TO BE	44
EXPERIMENT 23 – ELECTRIC MOTOR 1	46
EXPERIMENT 24 – ELECTRIC MOTOR 2	47
EXPERIMENT 25 – CAN MAGNETISM PRODUCE ELECTRICITY?	48

EXPERIMENT 26 – ON, OFF-OFF, ON.....	50
EXPERIMENT 27 – WHAT IS ELECTRICAL POTENTIAL DIFFERENCE?	53
EXPERIMENT 28 – THE MAXIMUM POTENTIAL ENERGY OUTPUT OF A BATTERY	55

The Ministry of Education wishes to acknowledge the work of the consultations on selecting the Microscience Experiments for Biology, Chemistry and Physics which are relevant to the national curriculum.

Participants

Name	Institution
Mr. Gregory Blyden	Faculty of Natural Sciences - University of Guyana
Mr. Mohandatt Goolsarran	Ministry of Education - NCERD
Mr. Navindra Hardyal	Queens College
Mr. Sirpaul Jaikishun	Faculty of Natural Sciences - University of Guyana
Ms. Petal Jetoo	Ministry of Education - NCERD
Ms. Noella Joseph	Cyril Potter College of Education
Ms. Samantha Joseph	Faculty of Natural Sciences - University of Guyana
Mr. Azad Khan	School of Education and Humanities - University of Guyana
Mr. Patrick Ketwaru	Faculty of Natural Sciences - University of Guyana
Professor Lloyd Kunar	Physics Department - University of Guyana
Mr. Marvin Lee	Queens College
Mr. Andrew Mancey	School of the Nations
Mr. Gary Mendonca	Faculty of Natural Sciences – University of Guyana
M. Kamini Ramrattan	Richard Ishmael Secondary School
Ms. Wendel Roberts	Ministry of Education – NCERD
Ms. Medeba Uzzi	Faculty of Natural Sciences – University of Guyana

A Message from the Minister of Education



‘The steady decline of enrolment of young people in science is cause for concern, and it is in this endeavour that UNESCO’s work in Science Education aims to make a difference. In a world that is increasingly shaped by science and technology, the team recognizes this and has made it its mission to not only spread education but to make an interest in the Sciences a prominent and lasting feature wherever it is offered’. (UNESCO, 2011). One approach used by UNESCO is its **Global Micro-science Experiments Project** which provides developed and developing countries alike with new teaching tools. This Global Micro-science Experiments Project is a hands-on science education project that gives primary and secondary school students as well as university students the opportunity to conduct practical work in physics, chemistry and biology, using kits that come with booklets. The project thus contributes to capacity building, in areas where limited/no laboratory facilities are available. The experimental techniques that can be covered on a micro-scale include everything from separating the components of mixtures to measuring rates of reactions between chemicals.

The Ministry of Education, Guyana collaborated with UNESCO to initiate the Global Micro-science Experiments project as a pilot for fifteen secondary schools in 2012. Ninety-five percent (95%) of secondary schools are now equipped with the micro-science kits and supporting manuals. This project was embraced to support the Ministry’s drive to improve enrolment in the single sciences. A twenty percent (20 %) increase in student enrolment was recorded since the introduction of this programme. We remain committed to transforming Guyana through Science and Technology in Education.

Guyana now leads UNESCO’s Global Microscience Experiments Project in the Caribbean and is willing to partner CXC territories in providing assistance.

It is my sincere hope that this manual will be used to encourage interactive learning which fosters the development of critical thinking skills by students.

Hon. Dr. Priya D. Manickchand
Minister of Education
Guyana
April 2015

Introduction to the first Guyana version adaptation of UNESCO teaching and learning materials on micro science experiments

The contents of this document are recommended by the participants of UNESCO/Kingston/Ministry of Education, NCERD consultations on Micro-Science Experiments held in Georgetown (Guyana) on 27-30 June, 2011. The present materials correspond fully to the existing National Curriculum for teaching basic sciences at the different levels. The materials were selected by the participants of the working consultations. The participants worked with teaching and learning packages on microscience experiments which are available on UNESCO's website and are free for all types of adaptations and modifications. The different types of microscience kits donated by UNESCO/Kingston Office to Guyana can be used in practical classes. The experiments are classified according to grades and some were given first priority (refer to appendix 1). The 'priority one' experiments are recommended for the pilot of the microscience experiments. It is very clear that, new experiments can be developed and tested using the same kit, as proposed by the participants of the working consultations which included curriculum development specialists. Developing new materials can be recommended, as a second stage of the project development. It is noted that the microscience experiments, as a new methodology for hands on laboratory work by students, can work in conjunction with macroscience experiments. Furthermore the microscience kits can be used by teachers for demonstration purposes. We hope, that the Science Teachers in Guyana will find the microscience experiments methodology and teaching and learning materials, interesting and of great value for the enhancement of science education.

Participants of the working consultations

May 2012

EXPERIMENT 1 – GET TO KNOW YOUR MICRO-ELECTRICITY KIT

CSEC OBJECTIVE (S): Section D – Objectives 4.1-4.4

Grade Level - 9

In the old educational system, this would not be a learning Activity. But in the light of the Outcomes Based Education System, this is a most valuable Activity, where learners can practice, investigate and explore with the kit. This is a great opportunity to assess skills.

OVERVIEW OF THE ACTIVITY

In this Activity, learners will meet the different components of the micro-electricity kit. They will explore the role of each component. They will investigate ways to make the components work in simple electric circuits.

WHY DO WE USE ELECTRIC CIRCUITS?

1.
 - a) For example, an electric heater, the stove, the fan, the light torch, the portable radio, etc. Challenge learners to think of devices which work with the mains or with batteries.
 - b) The heater and stove for heating, the fan for motion, the torch for light, the radio for sound.
 - c) It does not matter if learners use the wrong terms, as long as they realise that transformations/changes take place in the electrical device as soon as it is switched on. In the heater and stove, electrical energy transforms into thermal energy, in the fan into mechanical energy, in the torch into “light” energy, in the radio into “sound” energy (light and sound are not forms of energy, they transfer energy like all waves, but we can use the terms for the time being).

WHAT IS AN ELECTRIC CIRCUIT?

2.
 - a) No, this is not a circuit and there is no electric current in the wire-loop.
 - b) Phoka must connect a power supply, like a battery/cell. Learners will have ideas based on past experience and knowledge.
 - c) Yes, now there is a current in Phoka’s wire-loop.
 - d) Yes, this is a useless circuit. No device is connected to the circuit, to produce an effect, to transform the electrical energy, to show something is happening - a change!
 - e) Learners after completing the questions 2a to d, should come to the conclusion that:

An electric circuit is a closed conducting path, which is made out of three parts:

- a source of power,
- an electrical device which transforms the electrical energy into “usable” forms,
- the connecting wires (or other suitable connectors), which complete the path between source and device and make the transfer of energy possible.

Usually, learners do not feel comfortable with the concept of energy. They will possibly use the concept of the electric current when describing an electric circuit. From time to time, challenge learners to think in terms of energy, in order to build on the concept. Research has also shown that using current as the starting point to learn electricity, leads to several misconceptions. After all current itself is a difficult concept. Learners usually think of current as something that flows in the circuit.

4-5 Learners are expected to justify and reason why they have put a component into a certain category. Let the learners explore and find their own ways of how to use the components. They might have some good ideas! In the meantime, you may assess their improvisation, handling of apparatus and group-work skills. Learners will discover the use of more specialised components in the activities to come.

EXPERIMENT 2 – LIGHTEN UP, PREDICT AND EXPLORE

CSEC OBJECTIVE (S): Section D – Objectives 4.1-4.4

Grade Level - 9

OVERVIEW OF THE ACTIVITY

In Part A of this Activity, learners will be shown several diagrams of bulbs and cells. Their task will be to predict which diagrams represent a complete circuit. In other words, they must predict in which diagrams the bulb/s will glow. They will discuss the reasons why with the other members of their group. In Part B of this Activity, they will use components of the micro-electricity kit to construct simple circuits to test their predictions in Part A.

PART A

Bulb	Your Prediction	Group's Prediction	Observation	Comments
A	No			
B	No			
C	No			
D	No			
E	No			
F	Yes			
G	Yes			
H	Yes			
I	No			
J	No			
K	Yes			
L	Yes			
M	No			
N(1)	Yes			
N(2)	Yes			

PART B

3. a) Let the learners use the components of the micro-kit as they please. Let them find ways to construct each circuit. This is a good opportunity to assess their improvisation and reasoning skills.
4. Learners must mention the need for a closed circuit or loop, connecting the positive terminal of the cell to one terminal of the bulb (no matter which) and the negative terminal of the cell to the other terminal of the bulb.

EXPERIMENT 3 –CAR HEADLIGHTS

CSEC OBJECTIVE (S) : Section D – Objectives 4.1-4.4

Grade Level - 9

OVERVIEW OF THE ACTIVITY

In this Activity learners will discuss how the two main headlights of a car work. They will then draw a picture showing a simple circuit of the two headlights and the car battery. They will then use the micro-electricity kit to test their circuit.

This is an exploratory activity. Hopefully, in their discussions the learners will arrive at the conclusion that the car headlights need to be connected in such a way that if the one headlight goes out the other stays on (in other words, a parallel circuit).

The learners have not being taught about the difference in bulbs connected in series or in parallel. If their diagram shows the bulbs in series when they use the micro-electricity kit they will soon learn that car headlights are connected differently.

ASSESSMENT - Collect the groups' notes and sketches of their circuits. Decide on the criteria you will use to assess whether the learners meet the mentioned outcomes.

In the table below is an example of levels for the circuit diagrams.

Level 1	Level 2	Level 3	Level 4
Open circuit with actual components drawn in series	Closed circuit with actual components drawn in series	Closed circuit with actual components drawn in parallel	Closed circuit with symbols of components drawn in parallel

You may wish to add more levels. This is an example of a group assessment. You can choose any aspect of the Activity to assess. If you wish to assess a learner rather than the group you can ask the learner to explain how the circuit drawn by the group represents the workings of the car headlights.

ASSESSMENT - A number of learners may find this part of the Activity frustrating. When they try and make an extra path they may short circuit the bulbs. This means neither of the bulbs glow because there is no current in those branches with the bulbs. The current is in the part of the circuit without the bulbs (the extra metal strip). Through trial and error (and a little bit of guidance from you) they will overcome the problem. In the table below is an example of levels for the micro-electricity circuits.

Level 1	Level 2	Level 3	Level 4
Closed circuit with bulbs in series	Closed circuit with bulbs in parallel but there is a short circuit and the bulbs do not glow independently of each other	Closed circuit with two bulbs in parallel. Each bulb can glow independently of the other.	Closed circuit with two bulbs in parallel. Each bulb can glow independently of the other. A switch is introduced.

Another aspect you could assess is the manipulation of the micro-electricity kit. In the table below is an

example of levels of micro-electricity kit manipulation.

Level 1	Level 2	Level 3	Level 4
Do not use combo plate or springs. Hold circuit components.	Partly use the combo plate but still hold parts of circuit.	Use combo plate to support all circuit components; clumsy manipulation of components especially springs	Use combo plate to support all circuit components; controlled manipulation of components

1. Hopefully, the majority of learners have constructed a parallel circuit for their car lights. The importance of the independent glowing of the bulbs (car lights) should be part of the learner's explanation for their type of circuit. An example of the circuit is given below.
2. The learners may want to include the voltage (12 V) of the car battery on their circuit diagrams. You can collect their circuit diagrams to assess how they have drawn their circuit diagrams using the symbols information supplied. Draw up your own criteria for this assessment.

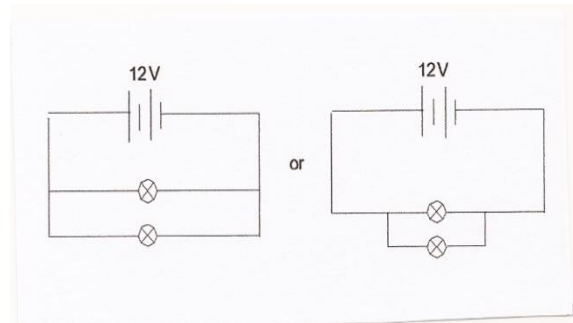

This Activity is a nice way to introduce learners to circuit diagrams. If the learners already know about circuit diagrams etc, ask them to leave out this question.

EXPERIMENT 4 – MAKING AN ELECTRIC CURRENT DETECTOR

CSEC OBJECTIVE (S) :

Grade Level - 9

OVERVIEW OF THE ACTIVITY

In this Activity learners will make an electric current detector which they will test on various objects around them. If a substance lets a current flow in it, it is called a conductor. If a substance does not let a current flow in it, it is called an insulator.

What to discuss

1. Learners should discuss each component of their detector. The cell supplies electrical energy, the copper strips are components of the circuit along which the current transfers energy, the bulb lights up when the circuit is closed by a substance that conducts electricity. The importance of a closed circuit must be mentioned.
2. This question is given to the learners to prevent them thinking that conductors are only solids. They may mention the gases in fluorescent tubes which light up because they conduct electricity. The acid in car batteries, electrolysis, water conducts electricity. It is very dangerous if electrical wires or electrical appliances touch water.
3. The learners should identify a number of conductors and insulators and discuss their positive effects. Here are a few examples.

Conductors:

- electrical wires are metal, copper. They are a cheap and efficient way of transferring energy.
- technology: all the different kinds of electrical appliances we can buy, eg, electric kettle, washing machine, toaster, television, computers, etc
- electric trains instead of steam/coal trains
- power lines
- the battery in a car
- lightning conductors

Insulators

- the plastic cover around electrical wires of all electrical appliances.
 - the materials used to construct electrical appliances. There are many, many examples here.
- We would not be able to use any electrical appliance if it conducted the current in it.

EXPERIMENT 5 – THE CURRENT IN A SERIES CIRCUIT

CSEC OBJECTIVE (S) : Section D – Objectives 4.1-4.4

Grade Level - 9

OVERVIEW OF THE ACTIVITY

In this Activity learners will set up a series circuit. They will observe the brightness of a light bulb placed at different points in the circuit.

Bulb position	Brightness Prediction	Bulb brightness
Before switch		bright
After switch		bright
Before battery		bright

1. Many learners believe that current gets used up as it flows in a circuit. The strength of the current remains the same. What gets used up is the electrical energy that is transferred to the light bulb by the current.
2. Most learners will predict that their bulbs will glow dimly. In actual fact, the bulb doesn't glow at all. This could lead the learners to believe there is no current in the circuit. The LED will show that there is a very small current in the circuit.
3. This task was included as resistors will be used in further Activities.

ASSESSMENT

One of the performance indicators of the outcome SO1 is 'carry out experimental procedures presented as diagrams'. You can assess the learners in their constructions of the circuits.

In the table below are some examples of possible levels of constructing and following instructions from diagrams.

Level 1	Level 2	Level 3	Level 4
The set up does not resemble the diagram	The set up resembles the diagram but the learners have omitted a component e.g., the switch	The set up resembles the diagram; the instructions on the diagram are not followed	The set up resembles the diagram; the instructions on the diagram are followed

EXPERIMENT 6 – LIGHT BULBS IN SERIES

CSEC OBJECTIVE (S) : Section D – Objectives 4.1-4.4

Grade Level - 9

ACTIVITY 6 - LIGHT BULBS IN SERIES

OVERVIEW OF THE ACTIVITY

In this Activity learners will set up a series circuit with one light bulb. They will then add more light bulbs in series to the circuit. They will observe the change in brightness, if any, of the light bulbs.

Bulb position	Brightness Prediction	Bulb brightness
1		bright
1 and 2		both equally dim
1, 2 and 3		all equally very dim

Note: All the bulbs used are identical 6 V bulbs. Unfortunately, they sometimes do not give the same results. Should learners find that the bulbs glow differently get them to chose three bulbs that glow the same.

1. Each time a bulb is added in series the current in the circuit is reduced. This means that the bulbs will glow more and more dim each time another bulb is connected in series. All the bulbs glow with the same dimness after each circuit change.

Note: Some learners may raise the point that an indicator light is different to the car headlights. It will glow differently to the two headlights, but it will still glow more dimly when there is less current in it.

2. a) The light bulbs act like the resistor. The resistor reduces the current in the circuit, and so do the light bulbs. We can think of a light bulb as a type of resistor.
b) The resistances of each of the light bulbs add up. This increased resistance reduces the current in the circuit.
3. Neither of the remaining bulbs will glow. The circuit is broken so there is no current in it.
4. **Disadvantages:**
 - The lights would glow very dimly and it would not be safe to drive the car at night time.
 - Also if one of the lights broke, the circuit would be broken and neither of the other two lights would work.
 - The energy drawn from the car battery would be used up very quickly.

Advantages:

- None with respect to a car. In other situations for example, the trip switch in a house, it is very important to have the trip switch in series.

EXPERIMENT 7 – LIGHT BULBS IN PARALLEL

CSEC OBJECTIVE (S) : Section D – Objectives 4.1-4.4

Grade Level - 9

ACTIVITY 7 - LIGHT BULBS IN PARALLEL

OVERVIEW OF THE ACTIVITY

In this Activity learners will set up a simple circuit with one light bulb. They will then add more light bulbs to the circuit. These bulbs will be connected in parallel. They will observe the change in brightness, if any, of the light bulbs.

Bulbs	'Glow' Prediction for each bulb	'Glow' of each bulb
Remove 1 bulb		remainder 2 bulbs glow
Remove 2 bulbs		remainder bulb glows

What to discuss

1. Light bulbs can continue glowing if one or more bulbs are removed in a parallel circuit. In a series circuit none of the remaining bulbs would glow.
2. a) Series: Christmas tree lights; torch
Parallel: ceiling lights in the home; traffic lights; street lights
b) If one Christmas tree light goes out, all the lights go out.

The circuit of a torch is a series circuit. There is only one path for the current.

The traffic lights and street lights are parallel circuits as any one of the lights in the circuits can be removed/broken and the rest glow.

The ceiling lights in our homes are connected in parallel. There is a wall switch which controls the on/off state of the lights. This means the light in the kitchen can be switched off while the rest of the lights in the house stay on.

3.a Answer: B

3.b Answer: D

3.c Answer: B

3.d Answer: C

ASSESSMENT

This Activity brings together the concepts of series and parallel series. You could assess learners on SO2 performance indicators. You could collect the above section to assess the learners' understanding of the concepts.

EXPERIMENT 8 – ONE AFTER THE OTHER, CAUSING A GREAT BOTHER

CSEC OBJECTIVE (S) : Section D – Objectives 4.12

Grade Level - 9

OVERVIEW OF THE ACTIVITY

In this Activity, learners will connect a different number of resistors in series to two cells. They will first connect one resistor, then two, then three and finally four resistors in series. In each case, they will measure the current in the circuit and the voltage across the resistors.

Their aim will be to:

- investigate the effect of an increasing number of resistors on the current strength
 - to compare the voltage across each connected resistor, to the voltage across all connected resistors
 - to find a relationship between the voltage across a single resistor and the current in the circuit
 - to compare the quantity V_x/I (where V_x is the voltage across a single resistor) for different currents in the circuit
 - to reflect on the meaning of the quantity V_x/I
1. a) The use of two multimeters gives more accurate results. If only one multimeter is available, learners should take these measurements one at a time. In this case, learners should complete the circuit with a copper strip or a connecting wire while measuring the voltage across the resistor.

NOTE: If possible, learners should take readings using two multimeters. An example of measurements, taken with **two** multimeters (one as an ammeter, the other as a voltmeter) and four 20 ohm resistors are shown in Table 1 below:

TABLE 1

Resistors connected in circuit	Current, I (mA)	Voltage across each resistor, V_x (volts)				Voltage across all resistors, V (Volts)
		V1	V2	V3	V4	
1	97.3	1.93	-	-	-	1.93
1+2	57.2	1.12	1.12	-	-	2.24
1+2+3	40.2	0.8	0.8	0.8	-	2.4
1+2+3+4	31.2	0.61	0.61	0.61	0.61	2.48

In Table 1a, are examples of measurements taken with **one** multimeter only. (Connect multimeter to measure current, disconnect ammeter, complete circuit, connect the same multimeter to measure voltage across resistors). Notice the error, especially in the last column, due to the considerable

resistance of the ammeter! Such an error would complicate things for learners in grade 9, who would fail to see that the ratio V_1/I (the resistance of the resistor) remains constant.

TABLE 1a

Number of resistors	Current I (mA)	V _x across each resistor (volts)				V across all resistors (Volts)	Calculate the sum V ₁ + V ₂ + V ₃ + V ₄ (V)	Calculate the ratio V ₁ /I (V/mA)
		V ₁	V ₂	V ₃	V ₄			
1	94.2	2.7	-	-	-	2.72	2.72	0.028
2	61.2	1.4	1.4	-	-	2.84	2.82	0.023
3	41.9	1	1	1	-	2.9	2.88	0.023
4	33.7	0.7	0.7	0.7	0.7	2.93	2.92	0.022

3. The graph represents how the current through a resistor (the first resistor) changes when the potential difference across the resistor changes. How did we change/decrease the potential difference across the resistor?

By adding extra resistors.

Challenge learners to think of the role of the extra resistors in the circuit. The best fit line, is a straight line passing through the origin. The origin is a point of the graph, since when no potential difference is applied to the

circuit, the current in the circuit is zero. The graph indicates that potential difference and current are directly proportional to each other. Challenge learners to think of the meaning of proportional and of directly proportional quantities.

Learners may mention the use of the graph by extrapolating the values of the current for a given potential difference across a resistor, and vice-versa, without actually measuring the values. Later on, learners will also use similar graphs to calculate resistance.

4. Learners should compare the data in each column. Table 1, suggests that:
- The current decreases with the more resistors we add in series.
 - The current decreases as the potential difference across each resistor decreases.
 - The potential difference (V), across all resistors increases slightly as the current decreases. In theory, the voltage across all resistors should remain constant. This discrepancy is due to the internal resistance of the cells and ammeter. The internal resistance decreases for decreasing current. This change causes the voltage to change/increase. Challenge learners to think of reasons causing this change, another resistance perhaps? Where does it come from?
5. a) Learners should calculate and tabulate the sum of the voltages across each resistor and

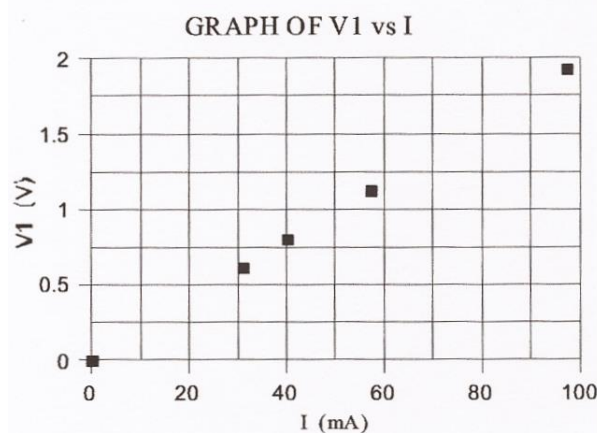

the ratio V_1/I for the first resistor. The following Table shows an example of calculations based on the measurements in Table 1.

Number of resistors	Current I (mA)	V across all resistors (Volts)	Calculate the sum $V_1 + V_2 + V_3 + V_4$ (V)	Calculate the ratio V_1/I (V/mA)
1	97.3	1.93	1.93	0.02
2	57.2	2.24	2.24	0.02
3	40.2	2.4	2.4	0.02
4	31.2	2.48	2.44	0.02

- a) The potential difference across all resistors is divided equally across each resistor, or that the sum $\Sigma V_x = V$.
- b) In the last column, the quantity V_1/I remains constant. This quantity indicates that for a given voltage, only a certain amount of current is allowed in the resistor. This is represented on the graph by the constant slope of the line.
6. b) Table 1 indicates that the current decreases with increasing number of resistors, or with decreasing voltage across each resistor. However, the table does not indicate how these quantities change in relation to one another. The type of relationship between current and voltage is illustrated by the graph. The table cannot “picture” the variation of the two quantities, nor is it suitable to formulate a conclusion on how the voltage affects the current.
7. An electrical conductor at a given potential difference V , allows only a certain amount of current I , so that the ratio $V/I (=R)$, remains constant. Learners are not expected to give the right answer, but to think and become more aware of the meaning of resistance step by step. In the next Activity, learners will build up their understanding of the concept of resistance.

EXPERIMENT 9 – FREE ELECTRONS ARE NOT SO FREE!

CSEC OBJECTIVE (S) : Section D – Objective 2.2

Grade Level - 9

OVERVIEW OF THE ACTIVITY

In this Activity, learners will use components from the micro-electricity kit to investigate how

- the thickness
- the length
- the material and
- the temperature

of a conductor affect the resistance it offers to an electric current. To do this, they will use metallic strips provided in the kits. They will work mainly with the three magnesium ribbon strips. These will be the metallic conductors under investigation.

NOTE 1: The internal resistance of the cells/battery increases as the cells go “flat” while learners take readings. The smaller the current they work with (or the greater the resistance), the longer the battery takes to go flat. We can expect a higher internal resistance for an ordinary carbon battery than for an alkaline battery. In fact, if learners are not quick enough, they can see the current drop as they take readings.

NOTE 2: If possible, learners should take readings using two multimeters at the same time (one as a voltmeter, the other as an ammeter). This would give more accurate sets of voltage and current readings, as the multimeter/ammeter has a considerable resistance. By removing the multimeter/ammeter to use it as a voltmeter, we increase the current in the circuit. In Investigation No 4 especially, it is advisable that learners use two multimeters.

NOTE 3: Because this Activity is very long, one suggestion would be to divide the class into four large “groups”. This way, the Activity can be done in one double lesson. Each group undertakes one investigation. Each group, reports back in class on their findings. The whole class then discusses the effect of the four factors under investigation, on the resistance of a conductor. Learners can then explain and discuss microscopically the observed effects in all four cases.

INVESTIGATION No 1 - THE THICKNESS OF A CONDUCTOR

In this investigation, learners will calculate and compare the resistance of magnesium strips of different thicknesses. To do this, they will connect one magnesium ribbon in a circuit, then two and then three ribbons placed together on top of each other. In each case, they will measure the electric current passing through the ribbons and the potential difference across the ribbons.

NOTE 1: The magnesium ribbons from the kit, demonstrate this effect with satisfactory and easily measurable results. Furthermore, the fact that thickness is being investigated by adding ribbons on top of one another, will provide a good insight to circuits with resistors in parallel, later on.

1. Learners must complete the circuit by connecting springs C and B with an extra insulated wire from the kit, or by connecting the red wire from the cells straight on to spring B. The multimeter must be connected between springs A (negative) and B (positive).

Set knob at position marked 20 V - since the cells provide about 3 volts.

The following table shows characteristic measurements, using components from the kits.

TABLE No 1 - The Effect of the Thickness of a Conductor on its Resistance

No of magnesium ribbons	Current (mA)	P. D. across ribbon/s (V)	Resistance of ribbon/s (V/mA)	Resistance of ribbon/s (V/A = ohms)
1	738	30	406	406
2	840	24	286	286
3	950	11	1158	116

2. a) In Joe's measurements the current is larger.
In Joe's measurements, the current does not show any significant difference as the number of strips increases.
- b) Joe's p.d. measurements are nearly zero, nearly no energy transfers to the copper strips. If learners calculated the resistance of copper strips it would be practically zero. Since the resistance of the copper strips is so insignificant, it does not really matter if there is one or two or three strips together, the difference would not be measurable in this investigation.
- c) Obviously copper has a very small, for all practical purposes zero resistance. Copper wires will not interfere with the current in the circuit. This is a question learners can be reminded of in all the following investigations.
3. a) With increasing thickness, the resistance decreases.
- b) Differences can be also dealt with after question 3c, when all groups report back in class explaining the effect.
4. Here learners are expected to give a microscopic explanation of the effect, not merely to describe the effect. For example, electrons in a thicker conductor have more space to move in, or that thicker conductors offer more area for the electrons to go through, therefore the current in the circuit is greater.

INVESTIGATION No 2 - THE LENGTH OF A CONDUCTOR

In this investigation, learners will calculate and compare the resistance of different lengths of magnesium ribbon. To do this, they will connect one, then two and finally three magnesium ribbons in a row. In each case they will measure the electric current passing through the ribbons and the potential difference across the ribbons.

The following table shows characteristic measurements, using components from the kits.

TABLE No 2 - The Effect of the Length of a Conductor on its Resistance

No of magnesium ribbons	Current (mA)	P. D. across ribbon/s (V)	Resistance of ribbon/s (V/mA)	Resistance of ribbon/s (V/A = ohms)
1	792	32	4040	404
2	725	48	6621	662
3	672	58	8631	863

- | | | | |
|--|--|--|--|
| | | | |
|--|--|--|--|
2. a) With increasing length, the resistance increases.
 - b) Differences can be also dealt with after question 3c, when all groups report back in class explaining the effect.
 - c) For example, electrons in a longer conductor meet more resistance as they travel a longer distance within the conductor, therefore the current in the circuit is decreased.
 3. Copper wires and strips have a negligible resistance (see also previous investigation, question A few copper strips in a row would not produce any measurable result.

INVESTIGATION No 3 - THE MATERIAL OF A CONDUCTOR

In this investigation, learners will calculate and compare the resistance of conductors made out of different materials.

This investigation is not going to be a fair test, as the thickness of the metallic strips in the kit is not the same, however, it will give a good qualitative feel of the differences in resistance between materials. And why not let the learners calculate the resistance of other devices in the kit. One important point of these investigations is that the current depends not only on the source of power, but also on the resistance of the conductors.

PREDICT

- a) This question gives the hint that zinc offers more resistance to the current than a similar copper conductor would offer. This is true, although zinc has also a fairly low resistivity.
- b) Learners could reason that copper has the smallest resistance since it is used in electrical circuits, and since they saw it in Investigation No 1. Magnesium ribbon should have the highest resistance, also from previous investigations, but also because we chose it for these investigations.

What to do

1. The diagram shows how to measure the current. If learners use the same multimeter to measure p.d., they should connect springs C and B with a connecting wire or strip to complete the circuit. They did the same thing in Investigation 1.
2. Note: Some kits have resistors of about 200 ohm resistance and others have resistors of about 20 ohm resistance (the ones with the golden stripe).
The following table shows characteristic measurements, using components from the kits. The measurements were taken using two multimeters.

TABLE No 3 - The Effect of the Material of a Conductor on its Resistance

Type of Conductor	Current (mA)	P. D. across conductor (V)	Resistance of conductor (V/mA)	Resistance of conductor (V/A = ohms)
Magnesium ribbon	935	14	150	150
Copper strip	983	1	1	1
Zinc strip	990	1	1	1
Bulb in bulb holder	928	17	183	183
LED	234	217	9274	9274
Resistor type	125	250	2000	20000
Resistor type	581	116	1996	1996

- | | | | |
|--|--|--|--|
| | | | |
|--|--|--|--|
3. Andile should use the zinc strips, because they offer much less resistance to the electric current.
 4. a) The potential difference in both circuits is the same, assuming that the internal resistance of the cells is negligible. Measurement of the real voltage using equipment from the kit, gave 2.29 volts across the bulb and 2.65 volts across the LED and 2.60 volts across a 20 ohms resistor.
b) In diagram A, because according to Table No 3, the light bulb offers less resistance than the LED.

INVESTIGATION No 4 - THE TEMPERATURE OF A CONDUCTOR

In this investigation, learners will calculate and compare the resistance of a conductor at two different temperatures.

PREDICT - Particles vibrate more vigorously around their fixed positions, provided that no change of phase takes place.

What to do

The following table shows characteristic measurements, using components from the kits. If ice-blocks or ice-cold water is available, learners can also take a measurement after cooling the magnesium ribbons.

TABLE No 4 - The Effect of the Temperature of a Conductor on its Resistance

	Current (mA)	P. D. across ribbons (V)	Resistance of ribbon/s (V/mA)	Resistance of ribbon/s (V/A = ohms)
Conductor in cold water	882	24	2727	273
Conductor at room temperature	840	24	2857	286
Conductor in hot water	850	32	3765	377

4. a) With rising temperature, the resistance of the material increases.
b) The resistance of the material should decrease continuously. Here, learners are expected to discuss, reason and exchange ideas. A good implication of low resistance would be the reduction of energy loss through heat (less collisions), etc.

EXPERIMENT 10 – WHAT GOES UP MUST FALL DOWN

CSEC OBJECTIVE (S) : Section A - Objective 5.2

Grade Level - 9

ACTIVITY 10 - WHAT GOES UP MUST FALL DOWN

OVERVIEW OF THE ACTIVITY

In this Activity, learners will investigate ways to make water flow through a flexible pipe, from one bottle to another. They will compare the flow of water with the flow of charge in a circuit.

1 Learners must discover by themselves that to begin with, the flexible pipe must be first filled with water, or else water flow will not be established. One way to do this, is to insert one end of the pipe in a bottle containing water, then suck the other end (like a straw) until the water reaches the mouth. They can then insert this end into the other bottle, which can be empty and kept at the same or lower level. Flow of water between the two bottles will be maintained, if the bottles are at different heights, or if the water levels inside the bottles are unequal.

Learners must investigate the effect on the water flow when the bottles are placed at different heights. The bigger the difference in height the greater the flow rate.

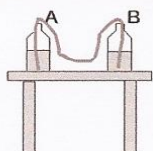

Diagram (a)
both bottles are on
the desk



Diagram (b)
both bottles are on
the floor

Learners must also interchange the height of the bottles. Always the flow takes place from higher to lower.

Learners could also discuss the potential energy of the water when the bottles are both placed either on a table or on the floor. What matters, is the difference in potential energy between two positions, not the potential energy at a certain position.

2a In the last two diagrams the bulb will glow, because there is current in the circuit. The charge can flow because a potential difference is maintained across the bulb. The positive charge will flow from higher potential (positive), to a lower potential (negative). In the first two diagrams, both ends of the bulb are at the same potential, charge will not flow.

2b,c Learners could add an extra cell in series to the first one. The potential difference across the bulb doubles. The charge flowing through the bulb "falls" through twice as much potential. It transfers twice as much potential energy to the bulb per unit time, the bulb transforms this energy into light energy and heat. Or, the charge is given twice as much energy, it flows faster and there are more collisions with the atoms of the bulb filament per unit of time. The bulb glows brighter and is hotter.

3 See diagram on the right.

4 This is a challenging task for the learners. Initially they might find it too difficult. Give them some ideas to begin with. As soon as they get started, they will be in deep discussion. Following are some examples of ideas! A falling stone is sometimes used to facilitate the task, and the moving charge in a simple electric circuit with a bulb. There are many more ideas learners might come up with.

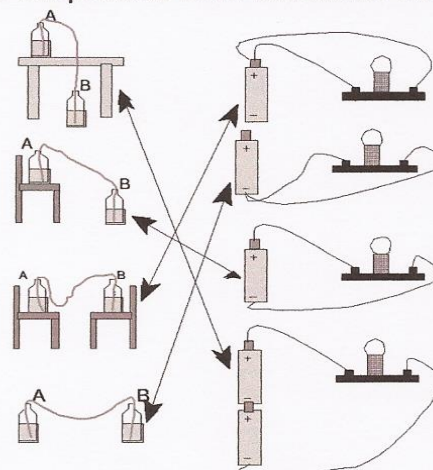
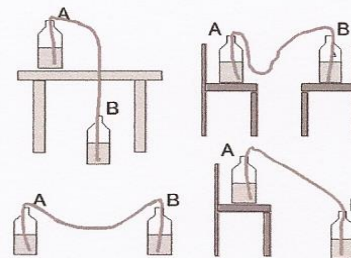

MASS IN A GRAVITATIONAL FIELD	ELECTRIC CHARGE IN AN ELECTRIC FIELD
There is only one type of mass.	Difference - There are two types of charge, positive and negative.
A mass is attracted to the ground by the force of gravity.	Similarity - The positive charge is attracted to the negative terminal by electrical forces. The opposite is true for the negative charge.
A mass at different heights has different potential energy.	Similarity - A charge at points of different potential has different potential energy.
In a gravitational field, a mass will move between two different points, if these points are at different heights.	Similarity - In an electric field, a charge will move between two different points, if these points are at different electric potential.
A mass will move from a position of higher potential energy to a position of lower potential energy.	Similarity - A charge will move from a point of higher potential energy to a point of lower potential energy. This is also true for the negative charge. A negative charge near the negative terminal of the cell is at higher potential than when it is near the positive terminal.
The potential energy of the stone as it falls, transforms into kinetic energy and when it hits the ground it's energy transfers to the surroundings.	Similarity - The potential energy of the charge as it "falls", is transferred to the bulb where it transforms into light energy and heat. (Also different in the way we take advantage of the transferred energy.)
A stone cannot fall if it moves on a flat surface, like the top of a table. The stone will fall when it reaches the edge of the table.	Similarity - A charge cannot "fall" when it moves in connecting wires with no resistance. A charge can "fall" when it reaches a region of resistance, like in the bulb filament.
The amount of kinetic energy and the work a falling stone can do when it reaches the ground, depends on its mass and on the height it falls from.	Similarity - The amount of energy the charge can transfer to the bulb, depends on the amount of charge and on the potential difference it goes through.
What gives the stone its initial potential energy? Someone or something who moved the stone to its initial height!	Similarity - What gives the charge in a circuit its potential energy? (An outside source "supplies" the potential energy.) The power source, the cells in our case. In the cells, chemical energy is transformed into electrical energy. The cells give electrical potential energy to the charge passing through it.
The falling mass system, does not form a closed loop.	Difference - The electric circuit is a closed loop.

EXPERIMENT 11 – THE CURRENT IN A SERIES CIRCUIT

CSEC OBJECTIVE (S): Section D – Objective 4.6

Grade Level - 9

ACTIVITY 11 - THE CURRENT IN A SERIES CIRCUIT

OVERVIEW OF THE ACTIVITY

In this Activity, learners are given a passage and a diagram from a textbook. The passage concerns the electric current. They will discuss the passage and the diagram in their group in order to find possible mistakes. They will then investigate ways to verify their conclusions using their micro-electricity kit.

1. Correct answer is c. When flow has been established, water particles do not accumulate at any point.
2. The current is the same at all points.
3. The text describes the flow of electrons in a simple electric circuit.

First column: “In order to see that the electric current is flowing, a bulb can be put in the circuit.”

Mistake 1. The current is not flowing, the charge is flowing.

Mistake 2. A bulb does not always glow when there is a current in the circuit, although this is not a real mistake.

“There are not enough electrons crossing both bridges to light both bulbs strongly...”

Mistake 3. It is not the number of electrons that determine the brightness of a bulb, it is their energy.

Second column: “More electrons could be added by adding more batteries to the circuit.”

Mistake 4. More batteries do not increase the number of electrons flowing in the circuit, they just increase their potential energy. Each new battery has its own charges of course, but this number of charges stays constant within each battery. A number of electrons leave its negative terminal, an equal number of electrons enter its positive terminal.

“Now the bulbs have more electrons and should be brighter.”

Mistake 5. Similar to mistake 3. Also note that the number of electrons entering the bulb filament, equals the number that exits. There is a constant number of electrons in the filament, determined by the number of free electrons in the filament. Electrons with more energy would move faster, but their number would be constant.

The Diagram: It is seriously wrong. Assuming that the connecting wires are made from the same material and are of equal thickness, the number of electrons on both sides of the bulb should be the same. The current is the same at all parts of the circuit! The diagram suggests that charge accumulates at some parts of the circuit. Look also at the stampede at the negative terminal of the battery!

4. The main problem is the accumulation of charge. Learners should consider measuring the current at different points in a series circuit, to prove that it is the same. This means that same amount of charge passes through each point of the circuit per second. Charge does not accumulate. Learners should connect the ammeter at both sides of a resistor or a bulb, record their measurements, compare them and come up with a conclusion.

5.

EXPERIMENT 12 – THE REAL & THE IDEAL WORLD

CSEC OBJECTIVE (S) : Section D – Objective 4.6

Grade Level - 9

OVERVIEW OF THE ACTIVITY

In this Activity, learners will discuss and investigate the accuracy of their multimeter. How can they minimize the error in their measurements? They will then make predictions of the current in a circuit and of the potential difference across various points in the same circuit. They will then test these predictions using their equipment.

Learners should work in groups of two or three and should combine the components of their microelectricity kits when necessary.

1. REFRESH YOUR MEMORY

- An ammeter should allow all the current in the branch of the circuit (where it is connected). It should have a negligible resistance.
- A voltmeter should not allow any current in the branch of the circuit (where it is connected). It should have a very large resistance.

2. TEST YOUR AMMETER

Learners might have ideas on how to test the ammeter. They should test their ideas using their equipment. If the ammeter does not interfere with the current (and assuming that both ammeters are identical), a second ammeter would also read 45 mA. However, when learners try this out, they will notice a drop in the current, in this case to about 33 mA. This indicates that the ammeter does interfere with the current, it reduces it, it has therefore a considerable resistance.

3. TEST YOUR VOLTMETER

If no current is allowed in the voltmeter, the reading of the voltage across the springs A and C should also be 2,85 V. There is no reason why the voltage should drop, since there is no transfer of energy (no current, the circuit is open). However, when learners measure the actual voltage, they will observe a drop of about a half (to 1,27 V). This indicates that there is a current in the circuit while the voltmeter is connected. The voltmeter interferes with the circuit. The voltmeter does not have an infinite resistance.

4. TEST YOUR CELLS

If the resistance of the LED was the only resistance in the circuit, the voltage across the LED would be the voltage supplied by the source, i.e. 2,80 V. However, the voltmeter reads about 2,62 V. The voltage is “shared” between the LED and some other resistance in the circuit. Where does this resistance come from? It originates in the cells. The cells have a resistance, an internal resistance. The internal resistance of the source affects the circuit, it reduces the total current! The internal resistance of a cell increases considerably the older or hotter the cell gets.

5. PREDICT

- Current in both bulbs should be 60 mA. The current splits into two equal parts, since the bulbs are identical.
- P.D. across CD = 1.5 V P.D. across BE = 1.5 V P.D. across AF = 1.5 V
P.D. across GH = 1.5 V P.D. across BC = 0 V P.D. across CH = 1.5 V
- Zero. They are all on the same side between bulbs and power source.

d) Zero.

6. TEST YOUR PREDICTIONS

The cell quickly goes “flat” when the circuit is closed. Measurements must be taken as fast as possible. If learners want to repeat measurements, they should wait a few minutes before they do so.

- a) Learners should connect the ammeter to measure the current in each bulb and the total current. They should compare the total current with the current in each bulb. They should mention the expected “splitting” of the current where the circuit branches and the big discrepancies between expected and measured values. Characteristic measurements using a single cell and three bulbs are given in the table below.

Number of bulbs	Total current I (mA)	bulb 1 - I1 (mA)	bulb 2 - I2 (mA)	bulb 3 - I3 (mA)	ΣI_x (mA)
1	130	130	-	-	130
2	140	114.5	114	-	228.5
3	152	97.5	94.7	94	286.2

- b) Learners should connect the voltmeter, to measure potential differences, across different pairs of points. They should compare the potential differences across bulbs and cell. They should mention the discrepancy between expected values and measurements. Measured values drop as more bulbs are connected in parallel. Characteristic measurements using a single cell and three bulbs are in the table below.

Number of bulbs	Voltage supplied by source (V)	bulb 1 - V1 (V)	bulb 2 - V2 (V)	bulb 3 - V3 (V)
1	1.41	1	-	-
2	1.4	1	0.92	-
3	1.36	0.78	0.76	0.75

TEST YOUR PREDICTIONS

The cell quickly goes “flat” when the circuit is closed. Measurements must be taken as fast as possible. If learners want to repeat measurements, they should wait a few minutes before they do so.

7. a) Learners should connect the ammeter to measure the current in each bulb and the total current. They should compare the total current with the current in each bulb. They should mention the expected “splitting” of the current where the circuit branches and the big discrepancies between expected and measured values. Characteristic measurements using a single cell and three bulbs are given in the table below.

Number of bulbs	Total current I (mA)	bulb 1 - I1 (mA)	bulb 2 - I2 (mA)	bulb 3 - I3 (mA)	ΣI_x (mA)
1	130	130	-	-	130
2	140	114.5	114	-	228.5
3	152	97.5	94.7	94	286.2

b) Learners should connect the voltmeter, to measure potential differences, across different pairs of points. They should compare the potential differences across bulbs and cell. They should mention the discrepancy between expected values and measurements. Measured values drop as more bulbs are connected in parallel. Characteristic measurements using a single cell and three bulbs are in the table below.

Number of bulbs	Voltage supplied by source (V)	bulb 1 - V1 (V)	bulb 2 - V2 (V)	bulb 3 - V3 (V)
1	1.41	1		
2	1.4	1	0.92	
3	1.36	0.78	0.76	0.75

EXPERIMENT 13 – THE INVESTIGATION

CSEC OBJECTIVE (S) : Section D – Objectives 4.1-4.5

Grade Level - 9

OVERVIEW OF THE ACTIVITY

In this Activity, learners will make three or four circuits with a different number of resistors in parallel. They will measure the current strength at different points of each circuit and the potential difference across the resistors. They will investigate the relationship between current and potential difference across resistors. Finally, they will compare a series circuit to a parallel circuit.

Learners should work in groups of two or three and should combine the components of their microelectricity kits where necessary.

1. TO INVESTIGATE

The following tables give characteristic measurements using equipment from the micro-electricity kit. Notice the smaller error in comparison to the error in the previous activity. This is due to the lower current in the circuit.

Task 1

TABLE 1 - MEASUREMENTS OF CURRENT

Number of resistors	Total current I (mA)	Resistor 1 I1 (mA)	Resistor 2 I2 (mA)	Resistor 3 I3 (mA)	Resistor 4 I4 (mA)	ΣI_x (mA)
1	21.9	21.9		-	-	21.9
2	28.2	14.9	14.9	-	-	29.8
3	31.4	11.6	11.6	11.6	-	34.8
4	34.2	9.2	9.2	9.2	9.2	36.8

Task 2

TABLE 2 - MEASUREMENTS OF POTENTIAL DIFFERENCE

Number of resistors	Voltage across springs A&B	Resistor 1 V1 (V)	Resistor 2 V2 (V)	Resistor 3 V3 (V)	Resistor 4 V4 (V)
1	1.22	0.52	-	-	-
2	1.22	0.37	0.32	-	-
3	1.22	0.28	0.27	0.26	-

	4	1.22	0.23	0.2	0.2	0.19	
--	---	------	------	-----	-----	------	--

Task 3 For this purpose, learners should complete a table like the following one. Learners should think of considering the average voltage across the resistors and the measurements of the total current in the circuit.

Number of resistors	Voltage across resistors, V (V)	Total current, I (mA)	Calculate the ratio V/I (V/mA)	Calculate the resistance, R (ohm)
1	0.52	21.9	0.02374	23.74
2	0.35	28.2	0.01241	12.41
3	0.27	31.4	0.008599	8.6
4	0.2	34.2	0.005848	5.85

2. SUMMARISE

The current divides between the branches.

The total current is the sum of all currents in the branches.

The more branches there are, i.e. the more components we connect in parallel, the more the total current increases.

The potential difference across components remains the same.

The total resistance decreases, the more resistors we connect in parallel.

3. COMPARE SERIES AND PARALLEL CIRCUITS

- In a series circuit the current is the same at all points. In a parallel circuit the current branches and in each branch the current is a fraction of the total current.
- In a series circuit the potential difference divides between components. The potential difference across components in a parallel circuit remains the same.
- In a series circuit the total resistance is the sum of the resistance of all connected components in series. The total resistance increases the more components we connect in series.
In a parallel circuit the total resistance decreases the more components we connect in parallel. The total resistance is less than the smallest resistance.
- In a series circuit, removing one component results in no current at all in the circuit. The circuit is "broken", and if circuit is closed the total resistance decreases.
In a parallel circuit, there are two or more loops or closed paths the current can follow. Removing one component from a branch does not affect the other branches, but does increase the total resistance.

EXPERIMENT 14 – POTENTIAL DIFFERENCE ACROSS POINTS IN A SERIES CIRCUIT

CSEC OBJECTIVE (S) : Section D – Objective 3.2

Grade Level – 9

OVERVIEW OF THE ACTIVITY

In this Activity learners will use their micro-electricity kits to investigate the relationship between the potential difference across a series circuit and the potential differences across each component of the circuit.

What to do

- Here is an example of a learner's table. If we add up the potential differences across the different components we get the same value as the potential difference across the battery (the potential difference across the series circuit) in the circuit.

circuit component	volts (V)
battery	2.5
circuit between A and B	0
light bulb, L ₁	1.4
light bulb, L ₂	1.1

What to discuss

- The value was zero. This means there was no transfer of energy between the two points. The voltmeter is designed to record the difference in electrical potential energy between the points.
- The sum of the individual potential difference values of the light bulbs is equal to the potential difference of the circuit.
 $V_{\text{circuit}} = V_1 + V_2$.
To get accurate results your learners need to work quickly. Once the battery gets hot, the potential difference readings change dramatically and can become meaningless.
- This question is included to reinforce what the learners learned in the previous activity. Part of the emf is used to move the charges through the battery. The difference between the emf of the battery and the potential difference of the battery is equal to the "lost volts".
- The resistors divide the total potential difference of the circuit into smaller quantities.
- $I_{\text{circuit}} = I_1 = I_2$. The current in a series circuit is the same at any point in the circuit. If an ammeter is connected in series at different points anywhere in the circuit the readings will be identical.

PREDICT & EXPLAIN

- The potential difference of the circuit will drop slightly. This is because the current changes which results in a change in the "lost volts". The potential differences across L₁ and L₂ will decrease but the sum of the potential differences across the three light bulbs, L₁, L₂ and L₃ will equal the potential difference of the circuit.
- The potential difference of the circuit will change. This is because the current will increase because the resistance of the circuit has decreased. With more current in the battery there

will be a greater resistance so the “lost volts” will increase. The potential differences across L_1 will increase and will equal the potential difference across the circuit.

ACTIVITY 15 - POTENTIAL DIFFERENCE ACROSS POINTS IN A PARALLEL CIRCUIT

OVERVIEW OF THE ACTIVITY

In this Activity learners will use their micro-electricity kits to investigate the relationship between the potential difference across a parallel circuit and the potential differences across the circuit’s parallel components.

What to do

4 Here is an example of a learner's table.

circuit component	volts (V)
Battery	2.5
Light bulb, L_1	2.5
Light bulb, L_2	2.5

5 Here are two ways in which the circuits could be represented.

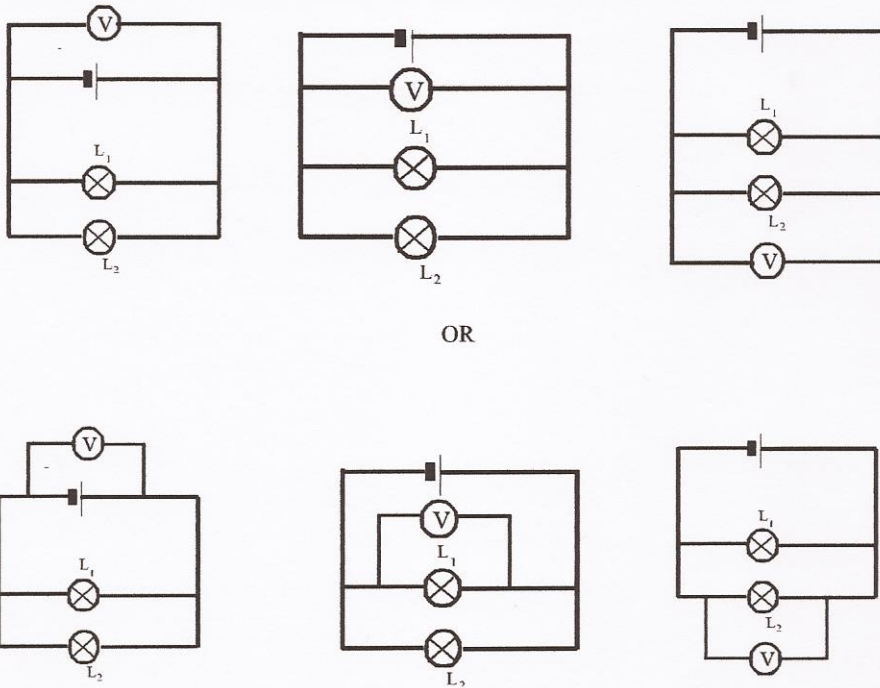

What to discuss

1. The potential difference value across the battery (V_{circuit}) is the same as the potential difference value across light bulb (V_1) which is the same as the potential difference value across the light bulb (V_2). $V_{\text{circuit}} = V_1 = V_2$.
2. $I_{\text{circuit}} = I_1 + I_2$. The current divides and a portion of the charge moves through the one light bulb

and the other portion moves through the second light bulb.

3. When the charges move through the battery energy is transferred to the atoms of the battery. This results in an increase in the temperature of the battery and leads to an increase in the resistance offered by the battery. With an increase in resistance more of the battery's emf will be used to move the charges against the increased resistance the battery.

4. $V = V_1 + V_2$ (or V_3) or $V_{\text{circuit}} = V_{\text{series}} + V_{\text{parallel}}$

The learners will recognise that there is only one potential difference reading for the two light bulbs, L_1 and L_2 in parallel. The rest of the circuit is a series circuit so the sum of the potential difference of the two light bulbs in parallel and the one light bulb in series, is equal to the potential difference across the circuit.

5. $I_{\text{circuit}} = I_1 = I_2 + I_3$

When the learners have completed these tasks call the class together. Ask members from various groups to write up their equations (relationships) on the board. The class must reach a consensus on the equations so they can be used later in circuit calculations. Select a learner to write the selected equations on a piece of flip chart paper and stick it on the wall for future use. You can be quite flexible with the symbols used to distinguish between the total circuit quantities and the individual circuit components. For example;

$V_{\text{circuit}} = V_1 + V_2$ series circuit

$V_{\text{circuit}} = V_1 = V_2$ parallel circuit

$V_{\text{circuit}} = V_{\text{series}} + V_{\text{parallel}}$ series - parallel circuit

$I_{\text{series}} = I_1 = I_2$ current in a series circuit

$I_{\text{parallel circuit}} = I_1 + I_2$ current in a parallel circuit

$R_{\text{circuit}} = r + R_1 + R_2$ resistance of a series circuit including internal resistance.

HOMework

- 1 B; When the switch S is closed the two 'right' resistors are in parallel. The resistance of the parallel resistors is less than that of one resistor. R_{total} decreases so I_{circuit} increases. The potential difference (V_{circuit}) is the emf of the battery as internal resistance is ignored and remains constant. For V_1 , R_1 is unchanged but I_{circuit} increases so V_1 will increase. For V_2 , $\text{emf} = V_1 + V_2$. With an increase in V_1 for emf to remain the same V_2 must decrease..
- 2 A; If P blows, V_1 is in series with the rest of the circuit. V_1 has a very large resistance and will then show a reading that is almost equal to the emf of the battery. Because there is no current in Q there will be no potential difference across Q and V_2 will not have a reading.
- 3 A; If S is closed the current short circuits R_2 and the charges move through the part of the circuit with S. This means there is no current, or negligible current in R_2 . The current is now in the portion of the circuit with the closed switch. R_1 is now the only resistor in the circuit so the R_{total} decreases. The current in R_1 increases, because current and potential difference are directly proportional the reading on V will increase (the resistance of the resistor remains unchanged).

EXPERIMENT 16 – OHM’S LAW

CSEC OBJECTIVE (S) : Section D – Objectives 4.7 – 4.9

Grade Level – 9

OVERVIEW OF THE ACTIVITY

In this Activity learners are going to investigate the relationship between potential difference and current in a resistor and find its resistance. They will set up a circuit one resistor (R_A) and a 3 V battery. They will use a multimeter as an ammeter to measure the current through another multimeter as a voltmeter to measure the potential difference across R_A . Then they will add a second resistor (R_B) in series with R_A and move the lead of the ammeter to include R_B in the circuit. They will then repeat the measurements of current through R_A and potential difference across R_A . Finally they will add a third resistor (R_C) in series and repeat the measurements of current and potential difference across R_A with R_C included in the circuit.

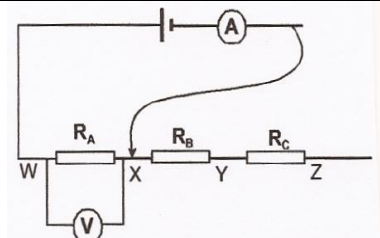

with
 R_A , and

To discuss before you start

1. By adding resistors we decrease the current in the circuit.
2. The potential difference is being measured across the resistor (R_A). It would be different if it was measured across other parts of the circuit. We want to look at the relationship between potential difference and current in the resistor and not of the complete circuit.
3. An increase in temperature affects the resistance of conductors and can lead to inaccurate results. To keep the temperature constant we need to stop for a few minutes between the readings to allow the resistor to reach room temperature again.
4. The current is the independent variable. The potential difference is the dependent variable.

What to do

4. Here are two examples of measurements using 220 ohm and 20 ohm resistors.

No of resistors	using 220 ohm resistors		using 20 ohm resistors	
	PDWX (V)	I ($\times 10^{-3}$ A)	PDWX (V)	I ($\times 10^{-3}$ A)
1	2.8	12.5	2.5	124
2	1.43	6.4	1.35	67
3	0.96	4.3	0.92	46

5. Following is a graph of the measurements given in the table above.

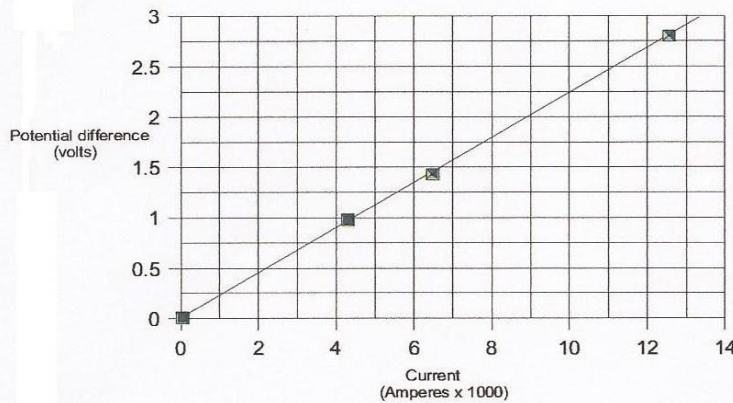

An example of the slope/gradient of the graph is:

$$\frac{(2.25 - 0) \text{ V}}{(10 \times 1000 - 0) \text{ A}} = 225$$

This value is very close to the value of 220Ω found for one of the brown resistors in the kit, using the colour code.

6 The results of this activity are usually good. Your learners will find their resistance results are very close to the value determined using the table.

7 Again the results will be comparable. If you use 220 ohm resistors, set the multimeter/ohmmeter on the 20k or 2000 setting. If you use 20 ohm resistors, set the multimeter/ohmmeter on the 200 setting.

Assessment

One of the performance indicators of the outcome SO1 is 'following written instructions supported by diagrams'. You can assess the learners in their constructions of the circuits and where they place the multimeters.

In the table below are some examples of possible levels for the performance indicator.

Level 1	Level 2	Level 3	Level 4
The set up does not resemble the diagram and the learners do not get any readings on the multimeters	The set up resembles the diagram, but the multimeters are connected incorrectly	The set up resembles the diagram but learners have difficulty following written instructions	The set up resembles the diagram; the written instructions are carefully followed and meaningful results are obtained

EXPERIMENT 17 – SOLENOIDS & ELECTROMAGNETS

CSEC OBJECTIVE (S) (S)(S): Objectives Section D 6.5 - 6.7

Grade Level - 10

OVERVIEW OF THE ACTIVITY

In this Activity, learners will investigate the magnetic field of an electromagnet. They will compare an electromagnet with a permanent bar magnet. They will investigate ways to increase the strength of an electromagnet. They will discuss practical applications of electromagnets.

THE INVESTIGATION - Learners should use wire from the copper coil provided in the kit. They can combine their coils if they need more wire. One set up per group is enough.

- The simplest way is to use the compass to identify the poles of the electromagnet. Learners can also use the right hand rule for the same purpose. Also see question 5, later on.
- Learners can move a compass needle at various positions around the magnet/electromagnet, to show how they “visualise” the shape of the magnetic field lines. Learners can make a drawing, showing the magnetic field lines. They should compare the shape and direction of the lines, inside and outside the permanent magnet and the solenoid. Note that the magnetic field lines in both cases, form closed loops, and that the field lines have a direction from north to south outside the magnets and from south to north inside the magnets.
- Learners should test their solenoid with and without the iron nail. They should prove, by picking up pins or by using their compass, that the field is stronger when the nail is inside the solenoid.
- Learners should discuss and try if possible, to increase the number of coils, and to increase the current in the solenoid by increasing the number of cells in series. Learners could also discuss the possibility of using more iron nails as a core and how they would do that, they should discuss different materials and how to investigate this option, and perhaps they should discuss the length of their solenoid. Does a longer solenoid mean a stronger electromagnet or not? Does a longer nail mean a stronger electromagnet?
- An electromagnet, can become stronger by increasing the current or the number of coils. A permanent magnet has a relatively constant “strength”. An electromagnet cannot be destroyed as easily as a permanent magnet. An electromagnet does not require special storage techniques, unlike the permanent (bar) magnets, which need to be kept at a certain orientation, in pairs, with a piece of soft iron at each end. An electromagnet is cheap in comparison with the cost of the permanent magnets. And perhaps the biggest advantage of an electromagnet, is that it works with the press of a switch! It is a magnet only when it is needed.
- The major difference is that the electromagnet works only when there is a current in the coil. It can be switched on and off, unlike a permanent magnet.

EXTENSION QUESTIONS

Time permitting, learners may choose to discuss some of the following questions. You can use these questions differently, for example, some learners can undertake to bring information about soft iron cores, or even try to make a soft iron core and then test it. Some groups can undertake to explain in class how a doorbell or a relay works, or even to find information on further applications of solenoids and electromagnets.

1. Magnetic objects can only be attracted by magnets. Magnets can be either attracted or repelled by other magnets. The unmagnetised rod will be attracted by both magnets, to both

their poles. The way to test the rods, is to look for repulsion. If two rods repel each other, both rods are magnets, and therefore the third one will be the unmagnetised one.

2.

- a) A device made out of several loops of wire, usually all on the same plane, like the coil of copper wire in the micro-electricity kit.
- b) A device made out of several loops of wire, forming an elongated coil. Sometimes, the solenoid is also called a "coil".
- c) It is a solenoid with a core inserted in it, to increase the magnetic field of the solenoid. The core is usually made out of soft iron.
- d) Learners most possibly don't know what soft iron is. However, many learners will ask this question. Learners may discuss the term, or find information in books or even ask skilled people technicians, electricians, etc.).

Soft iron refers to the ability of an iron core to become magnetised very fast, but also to lose its magnetism very fast! So it is soft only in a magnetic sense. This is what we want with an electromagnet: To become magnetised and to lose its magnetism, as soon as the current is turned on and off.

Iron that holds its magnetism, even when there is no external magnetic field, is called "hard iron". This can be used for permanent magnets.

Iron materials become "soft" after they undergo a special heat treatment. (It also depends on how the iron material is being alloyed and on other factors - the exact mechanism of how this is achieved is complicated and beyond the scope of this level.)

Learners can "soften" their iron nails, by leaving them in red hot coals overnight.

3. As soon as the current in the circuit is switched on, a magnetic field is produced inside and around the solenoid. The iron core inside the magnetic field of the solenoid becomes magnetised very fast. It becomes a magnet and its magnetic field adds to the magnetic field of the solenoid. This results in a much stronger magnetic field.
4. a) The magnetic field lines outside a solenoid or magnet, have a direction from north to south. Here the direction of the field is given in the diagram. The north pole of this solenoid is on the right, the south pole on the left. You may chose another diagram, where the direction of the field lines is not given. In this case, learners must apply the right hand rule from the previous Activity, to find the direction of the field lines. They can then determine the poles.
b) here is a hand rule (right hand solenoid rule) to determine the north and south poles of a solenoid, but it is not widely used, since one can determine the polarity of the solenoid using the previous right hand rule.

Learners have the ability to come up with the rule: Holding the solenoid with the right hand, fingers pointing in the direction of the current in the coils, then the thumb points to the magnetic north of the coil!

EXPERIMENT 18 – FEDERAL BUREAU of INVESTIGATIONS, FBI

CSEC OBJECTIVE (S): Section D - Objectives 7.4 -7.7

Grade Level - 10

OVERVIEW OF THE ACTIVITY

In this Activity, learners will place a current carrying wire, made of steel-wool, between two magnet magnets. They will investigate what happens to the wire, when the direction of the electric current in the wire changes, and when the direction of the magnetic field produced by the magnets changes. They will meet the left hand rule, and they will test if it is valid in this experiment.

What to do

1. Learners need to know the direction of the magnetic field they apply in their set-up. Learners can test the poles using a magnetic compass (included in the micro-electricity kit). The south pole will attract the north pole of the compass. As soon as they identify one face of a magnet, they can identify the others by testing through attraction or repulsion.

PREDICT

5. a) To the right (from spring A to spring B), conventional current is from positive to negative.
c) They are perpendicular to each other.
6. Learners might not know exactly what will happen, but they should expect a force exerted on the wire by the magnetic field of the magnets. They know that an electric current produces a magnetic field and that magnets exert forces on each other. They may say the wire will move. When reversing the current, a force should be exerted on the wire, but in the opposite direction.

WHAT HAPPENS?

7. The steel-wool wire will move upwards. Learners must discuss this and mention that an upward force acts on the wire. This force is exerted by the magnetic field of the two magnets. Reversing the current in the steel-wool wire: The current can be reversed by connecting the red wire of the battery to spring B and the black wire to spring A. In this case, the steel-wool wire will move downwards. The magnetic field, exerts a downward force on the wire. Reversing the magnetic field: By flipping the magnets over, or by exchanging their positions on the combplate.
8. Let the learners observe by themselves that these quantities are all perpendicular to each other.

EXTENSION QUESTIONS - THE CHALLENGE!

1. a) Downwards.
b) The learners must draw the diagram by themselves. They can draw the diagram at any angle they wish. An example of a diagram learners are likely to draw is shown on the right:
2. a) See diagram on the right.
b) The forces on the left and right sides of the loop, F_1 and F_2 , cancel each other out. The net force acting on the loop is F_3 , so the loop will move downwards.
3. Yes, each moving charge can be considered as a tiny current.
a) Learners must remember that when we say current we mean the conventional current,

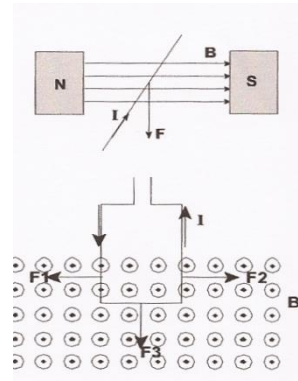

right:

which is the flow rate of positive charge. The proton is a positive charge, its velocity is in the same direction with its current. The electron is a negative charge, its velocity is in the opposite direction with its current.

- b) The proton will experience a force with a direction into the page “X”
The electron will experience a force with direction out of the page

EXPERIMENT 19 – COMING ATTRACTION

CSEC OBJECTIVE (S) : Section D – Objective 7.4

Grade Level - 10

OVERVIEW OF THE ACTIVITY

In this Activity, learners will test the effect of an electric current on a magnetic compass. They will first make a simple circuit. They will then put a magnetic compass at different positions around the circuit. Their task will be to discover if there are such areas around the circuit where the pointer of the compass deflects.

Position of magnetic compass	Observations
On top of (black) negative wire	pointer deflects (to the left in diagram)
Under negative wire	pointer deflects (to the right in diagram)
Next to negative wire	no deflection
On top of (red) positive wire	pointer deflects (to the right in diagram)
Under positive wire	pointer deflects (to the left in diagram)
Next to positive wire	no deflection
On top of the bulb	slight deflection
Next to bulb	no deflection
On top of the battery	slight deflection on top of the battery
Next to battery	slighter deflection next to the battery
Other (specify)	

4. Pointer deflects to the right.
5. a) Correct answer is iii.
b) Pointer deflects to the left. The deflection is similar in magnitude to that in a, but in opposite directions.

ASSESSMENT - Choose two groups to assess their process skills. The following table gives an example of criteria you might wish to use.

Level 1	Level 2	Level 3	Level 4
Learner completes a closed circuit, does not understand where to place compass	Learner places compass in a variety of positions, completes table only when sees a deflection	Learner completes table successfully, has difficulty aligning the pointer with the wire	Learner understands diagrams, places compass in a variety of positions not shown in diagram, completes table, finds a way to align the pointer with the wire before the current is switched on

What to discuss

1. a) Directly on top or under the wires, as well as on top of the battery where the deflection is the biggest. Hopefully learners noticed that there was deflection in all parts of the circuit, even on top of the bulb or battery. It is not the device/component that causes the deflection, but the electric current which passes through the device.
 b) When the compass is placed at the sides of wires.
 c) No. The pointer points north.
2. Learners should suggest that perhaps a greater current will result in greater deflection, which is true!
3. If learners answer a magnet, it should be an acceptable answer. More precisely it is a magnetic field. The compass points to the north, because it is inside the magnetic field of the Earth. Any other magnetic field, like that of a bar magnet for example, also deflects the compass accordingly.
4. When an electric current passes through the circuit, the pointer deflects. This means that the electric current **must produce** a magnetic field which deflects the pointer.
 Note: It is not the current that exerts a force on the pointer; it is its magnetic field!
5. An electric current produces a magnetic field.

EXPERIMENT 20 – FIELDING

CSEC OBJECTIVE (S) : Section D – Objective 7.5

Grade Level - 10

OVERVIEW OF THE ACTIVITY

In this Activity, learners will use their magnetic compass to investigate the magnetic field around a current carrying wire. They will investigate the shape and direction of this field.

North.

6 The arrows should form a circle around the vertical wire



In the vertical wire, the conventional current points upwards.

In the vertical wire, the conventional current now points downwards.

The arrows should form a circle around the vertical wire



ASSESSMENT

Choose a small number of groups to assess their process skills. The following table gives an example of criteria you might wish to use.

Level 1	Level 2	Level 3	Level 4
Recognize the components of the kit, lack initiative, need to see the work of others, need guidance, do not understand why compass points north	Follow instructions carefully, but make mistakes, (like connecting the cells the wrong way), give up when problems arise (asking what to do)	Read carefully and follow instructions from diagrams successfully, complete circuit in a reasonable time	Feel comfortable following instructions straight from diagrams, complete circuit fast, they improvise and find better solutions, try further investigation

What to discuss

2. See next page.
3. Due north. The pointer will not be deflected, as it is vertical to the magnetic field lines.
4. a) The electric current produces a magnetic field.
b) It will be interesting to hear what learners think of this effect or what they might know already, since up to now the magnetic effect of a current has not being put into context.

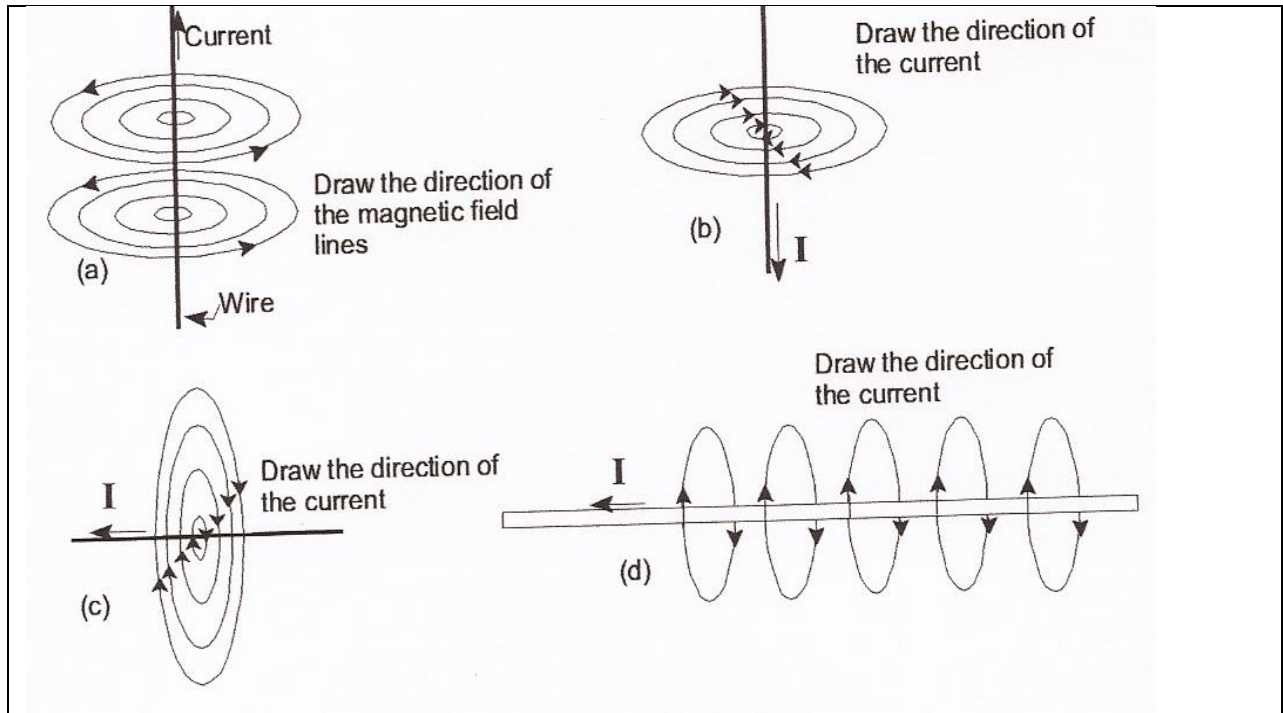

ASSESSMENT

Choose two groups to assess their understanding. The following table gives an example of criteria you might wish to use.

Level 1	Level 2	Level 3	Level 4
Needs guidance to understand the right hand rule. Is able to identify conductors and field lines in the diagrams.	Sees the analogy between the diagram of the straight current carrying conductor and that of the right hand rule. Is confused with the difference in appearance of the field lines in the question diagrams, but can use the right hand rule in simple cases.	Is able to relate right hand rule to this activity using the right hand. Is able to find directions of current and field lines on rest of diagrams with ease.	Can answer questions number 2 and 3 of the discussion. Reflects on more complicated cases, (like when the conductor is not straight).

EXPERIMENT 21 – THE STRONGEST OF THEM ALL!

CSEC OBJECTIVE (S) : Section D – Objectives 7.1-7.3

Grade Level - 10

OVERVIEW OF THE ACTIVITY

In this Activity, learners will place a magnetic compass in the centre of a current carrying coil to see how the pointer is affected. They will then make an electromagnet. They will investigate ways to make the electromagnet stronger.

- North. The compass is inside the magnetic field of the Earth.
 - The pointer should be aligned with the perpendicular axis to the plane of the coil. As is in this diagram, the pointer should point away from the circuit. It is enough if learners notice the deflection of the pointer and take notice of the direction of the pointer to compare with the next question.
 - As previously but in the opposite direction.
- The compass deflects slightly.
 - The pins most possibly are not attracted.
- The deflection of the compass is more evident. The magnetic field is stronger.
 - The pins (one or two) should be attracted to the nail. The nail can pick up one or two pins.
- This time, the magnetic field is stronger. Learners will notice that when the iron nail is inside the straw, they can easily pick up the steel pins. This time they can pick up about three pins at a time.
- The table below gives an idea of how learners could tabulate their observations.

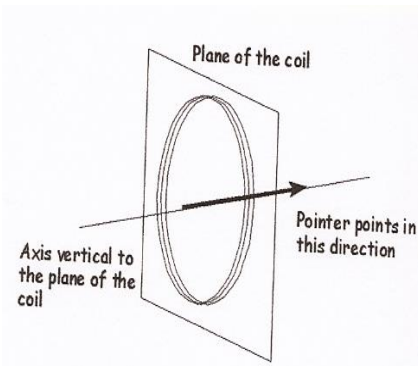

straw	windings	compass/comments	pins/comments
empty	about 30 windings	deflects weakly	does not pick up pins
with iron nail	about 30 windings	deflects more strongly	picks up two pins
empty	about 60 windings	deflects weakly but more than when fewer windings	does not pick up pins
iron nail	about 60 windings	deflects strongly	picks up three pins
steel nail	about 60 windings	deflects strongly	picks up three pins
copper foil	about 60 windings	deflects weakly as when empty	does not pick up pins
magnesium foil etc.	about 60 windings	deflects weakly as when empty	does not pick up pins

--	--	--	--	--	--

ASSESSMENT

Choose a small number of learners to assess their process skills. The following table gives an example of criteria you might wish to use.

Level 1	Level 2	Level 3	Level 4
Learner can complete a closed circuit, cannot understand diagrams	Learner is able to make an electromagnet, needs guidance, records some data	Learner completes the table, but does not mention the effects in detail	Learner completes a table, records core, number of windings, the effect on compass and pins, criticizes constructively and explains to others

What to discuss

- Learners should realize that an electric current, produces a magnetic field. The electromagnet acts like a bar magnet, with a similar magnetic field. Because this magnet is due to an electric current, it is logical that it will be called an electromagnet.
 - Yes, although not as strong as with an iron bar/nail inside it. Learners have seen the magnetic compass deflect.
 - By winding more turns of copper wire around the straw and nail.
- Learners might try this. The use of a stronger battery would result in a bigger current, which in turn would produce a stronger magnetic field. Learners saw this in previous Activities. A stronger magnetic field will produce a stronger electromagnet.
- Learners can suggest using a compass. The south pole will attract the tip of the pointer; the north pole will attract the tail of the pointer. Learners could also use the right hand rule.
 - By connecting the electromagnet the other way round to the cells.
- See diagram on the right.
- The current and the number of windings of the solenoid. Furthermore, the polarity of the electromagnet depends on direction of the electric current.

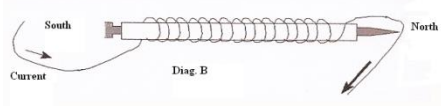

the

ASSESSMENT

Choose two groups to assess their understanding. The following table gives an example of criteria you might wish to use.

Level 1	Level 2	Level 3	Level 4
Learner distinguishes Between electromagnet and solenoid	Learner mentions factors that affect an electromagnet	Learner can find the polarity of the electromagnet using a compass	Learner uses the right hand rule and finds the polarity of the electromagnet, explains well to others in the group

EXPERIMENT 22 – AMMETER, TO BE AND NOT TO BE

CSEC OBJECTIVE (S) : Section D – Objective 4.6

Grade Level - 10

OVERVIEW OF THE ACTIVITY

In this Activity, learners will first get to know their multimeter. When does it work as an ammeter? What range of currents does it measure? Then they will make simple electric circuits with components connected in series. They will use the multimeter to measure the current strength at different points of these circuits. Their task will be to discover if the current varies at different points of each circuit or not.

2. a) It is a thousandth of an ampere, $1\text{mA} = 1\text{A} / 1000$.
b) When we refer to extremely small things, invisible, subatomic, etc. For example, microscope, microcosm, microscale, $2\text{c } 1\,000\,000\ \mu\text{A} = 1\ \text{A}$, $1\,000\ \mu\text{A} = 1\ \text{mA}$
3. Point (i): To read the correct current, the ammeter must be connected in series with the bulb and cell, or else the current will branch.
Point (ii): A good ammeter should have a negligible resistance, like the connecting wires of the circuit. Learners are not too familiar with the concept of resistance, although they have met it before. They will meet this question again in Activity 7.
b) Diagram (a), because the ammeter must be connected in series in order to read the total current.
4. The ammeter will read the same current at all points, i.e. 130 mA. There are several misconceptions among learners, for example:
Electric charge is produced by the cell, therefore current is stronger closer to the positive terminal of the cell.
Another is that current is consumed by the bulb, so after the bulb the current is less. Also the concept of the flow rate is a difficult one and learners who have not grasped it might have some strange ideas!
5. In both questions, both switches must be closed to make any bulb glow. See also answer to question 4.

NOTE: If learners must measure the current in circuits where only bulbs (and no resistor) are connected, it is advisable to use one 1,5 cell. Two cells result in currents larger than 200 mA and the multimeter/ammeter cannot read them (it reads up to 200 mA).

This presents the following problem:

The specifications of the bulbs provided in the micro-electricity kit, are usually 6 V and 3 W. Two of these bulbs connected in series to a single cell will glow very dimly. The additional connection of the multimeter/ammeter, might cause the bulbs not to glow at all, because the instrument has a measurable resistance which adds to the resistance of the bulbs. However, learners will be able to take measurements of current even if the bulbs do not glow!

6. Learners should complete the circuit and take current measurements on both sides of the bulb. Learners must “cut” the circuit to connect the ammeter. Remind them of question 3b above. They should record their results, preferably in a table like the following:

Ammeter at point	Current (mA)	Prediction	Comments
B	1295	Current is very nearly the same at all points....
C	1301		

D	1290		compare with prediction
---	------	--	----------------------------

7. a) Learners can remove and replace the strips to simulate the action of an open and closed switch.

Switch S1 corresponds to strip 1 in the diagram (see learners worksheet).

Switch S2 corresponds to strip 2 in the diagram (see learners worksheet).

c) The other bulb stops glowing, an indication that there is no current in the circuit. It happens because the circuit is “broken” or “cut”. It is not a closed loop any longer.

8. A suggestion would be to remove strip 1 from the circuit, and in its place to insert the connectors of the multimeter in springs A and B. Repeat with the other strips. Learners must “cut” the circuit to connect an ammeter.

b) The three currents are the same. The current in a series circuit is the same at all points.

9. The current in question 6 is the same at all points.

The current in question 8 is the same at all points.

The cells and bulbs in both circuits are identical.

The current in q.6 is greater than in q.8. The difference must be due to the different number of bulbs in each circuit.

Removing one bulb, “breaks” the circuit. All bulbs go off.

Learners should conclude that the current in a series circuit is the same at all points. The current in a series circuit decreases when additional bulbs are added in series.

EXPERIMENT 23 – ELECTRIC MOTOR 1

CSEC OBJECTIVE (S) : Section D Objective 7.8

Grade Level - 10

OVERVIEW OF THE ACTIVITY

In this Activity, learners will make a simple DC motor which works without brushes. They will then discuss how the motor works.

What to discuss

2. a) It moves downwards.
- b) The wire on the left moves downwards, the wire on the right upwards.
- c) It rotates until it comes to a vertical position.
- d) See diagram below.

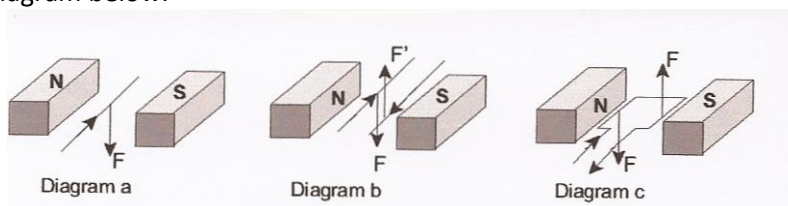

YOUR MOTOR

3. A motor must turn continuously in **one** direction! If the current in the coil is continuously in the same direction, we have a problem. This is because each time the coil passes through the vertical position, the forces would act to return the coil back to the vertical. The coil would stop vertically.
In most dc motors, we turn the coil by alternating the current every half turn of the loop. We do that by using a commutator and brushes, like in the following type of motor.
In this motor, we have no brushes. Instead we allow current in the loop only every half a turn. So for half the cycle, the loop turns due to its (rotational) momentum. For the other half cycle it turns because of the pair of forces which act in opposite directions (torque). If there was current continuously in the coil, (if the insulation was scraped off all around the wire), the loop would stop vertically and wouldn't rotate. Learners don't know about torques and momentums, but they can understand intuitively what the acting forces can do.

EXPERIMENT 24 – ELECTRIC MOTOR 2

CSEC OBJECTIVE (S) (S: Section D - Objective 7.8)

Grade Level – 10

OVERVIEW OF THE ACTIVITY

In this Activity, learners will make a simple DC motor which works with brushes and a commutator. They will then discuss how the motor works and they will compare this motor with the motor from the previous Activity.

With the help of the diagrams learners can estimate the size and position of the different parts of the complete motor. Learners should not waste time measuring and trying to be accurate.

The reason why we cover the shaft (i.e. the straightened paper clip or wire) with tape is to stop it from being slippery. This way the coil attaches to the shaft tightly.

If the motor does not work (coil does not turn) when the brushes are connected to the battery. The most common source of the problem is where the brushes touch the commutator. Pupils should check the following:

- (i) That the brushes touch the conducting strips of the commutator at the same time, one at each side - the most common problem!
- (ii) That the insulation of the two ends of the thin wire is scraped off properly.
- (iii) That the two small parallel copper strips of the commutator actually touch the bare ends of the thin wire, and not each other.

In most dc motors, we alternate the current every half turn of the loop. This causes the coil to turn continuously in the same direction. We do this by using a commutator and brushes, like in this motor. Every half turn, each commutator changes connection to the other brush. The current in the coil reverses every half revolution, as is needed for continuous rotation.

What to discuss

1.
 - a) By a permanent magnet (the magnadur magnets).
 - b) In the previous motor the current does not alternate, but there is current only every half a cycle. In this motor, the current alternates every half a cycle, because of the commutator and the brushes.
 - c) Only in motor 2.
 - d) Yes, in both motors the coils turn continuously in the same direction. See also the comments concerning the function of each motor.
 - e) Learners might have several ideas on how to make the motors stronger, like
 - by increasing the magnetic field (by adding extra magnets, or by replacing the magnets with stronger ones),
 - by increasing the current in the coil (by increasing the number of the cells in series),
 - by increasing the number of windings in the coil,
 - by adding a soft iron core in the coil
2.
 - a) See diagram on the right.
 - b) The two parallel sections of wire, experience forces in opposite directions. (Left force inward, right outward). This causes the loop to rotate about its vertical axis. The greater the current, the more the coil and the attached pointer will turn against the resistance of the spring (spring is attached to the pointer).

3. Electrical energy is transformed into mechanical energy.

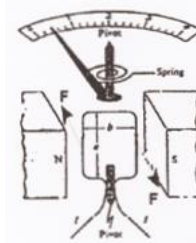

EXPERIMENT 25 – CAN MAGNETISM PRODUCE ELECTRICITY?

CSEC OBJECTIVE (S) : Section D - Objective 7.4

Grade Level – 10

OVERVIEW OF THE ACTIVITY

In this Activity, learners will investigate ways to produce an electric current in a coil of copper wire, with an electromagnet (or a magnadur magnet).

THE INVESTIGATION

- Learners must think of connecting the electromagnet to a source of power, like the two cells from the kit. There must be current in the electromagnet to produce a magnetic field. The coil should be connected to the ammeter. When the ammeter shows a reading, it indicates current in the coil. Learners most probably will mention that small currents should be expected, which is true. Not enough to light up a bulb from the kit. In this case, they should use a scale marked 200 mA or 2000 mA. If learners are not sure about the magnitude of the current, they should think of starting on a larger scale and reduce it if there is no reading.
Let learners explore, it is possible that they will induce a current. The given hint in the learners' worksheet will guide them to move the electromagnet or the coil. The magnadur magnet will induce a larger current. If stronger magnets are available in class, try them by all means.
- Learners could use a compass needle. If there is a current induced in the coil, it will produce its own magnetic field, which will cause the magnetic needle to deflect. If learners try this out, they must think of the interference of the magnetic field of the electromagnet. The electromagnet must be kept as far from the compass as possible. Learners could investigate a way to avoid this interference as a separate project. The diagram below suggests one way.

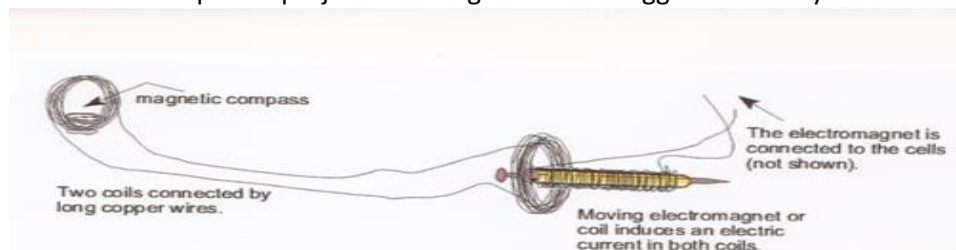

- Learners must mention that a current is induced in the coil, when the magnet or the coil moves. If they mention the word **change** in the magnetic field, or in the motion of the components, it is even better. It is the change in the number of magnetic field lines through the coil that induces the current in the coil. This change can be usually brought about by:

- moving the coil relative to the magnet,
- moving the magnet relative to the coil,
- rotating the coil, while inside a magnetic field,
- changing the shape of the coil, while inside a magnetic field.

The induced current will be of the order of a few milli- or micro-amps. Learners should notice the positive or negative readings on the ammeter, and they should comment on the direction of the current when the magnet approaches or leaves the coil and vice-versa. They should comment on the effect of the speed of the magnet or coil (whichever moves). Challenge learners if they run out of ideas - this is a difficult investigation, but don't give them the answers.

Learners must mention ways to increase the induced current, i.e. by increasing the windings in the coil, or by increasing the strength of the electromagnet, or by moving the electromagnet or the coil faster.

4. If learners succeeded to induce a current in the coil, they should have noticed that the current is induced only when something moves, either the coil or the magnet/electromagnet. It is the **change** in the magnetic field, or the change in the number of field lines that pass through the coil, that induces the current, not the magnetic field itself. This is something difficult to comprehend. One should imagine that scientists first tried magnetic fields of different strengths and orientations, without any success.

Challenge learners to think of Alex's comment at the beginning of this activity. "We can't get something out of nothing!" A change in the external magnetic field will induce a current in the coil. A change happens only when there is energy transfer.

5. b) Learners have perhaps an idea, or even heard of the words substations, transformers, step-up and step-down transformers. What do transformers do? Let them discuss their ideas. Later on, they will investigate transformers and learn more about induction.

THE CHALLENGE!

1. a) (a) To the right, (b) to the left, (c) to the left, (d) to the right.
 b) A current is induced in the coil in each case.
 c) Learners may use the right hand rule to find the direction of the current in the coil. The induced current is in such a direction, so as to produce a magnetic field that opposes the change brought about by the external field of the magnet (Lenz's law).
 d) Only when it moves relative to the coil.

EXPERIMENT 26 – ON, OFF-OFF, ON

CSEC OBJECTIVE (S): Section D – Objectives 4.1 - 4.5

Grade Level – 10

OVERVIEW OF THE ACTIVITY

In this Activity, learners will work in groups (2-3 people). Each group will read a short paragraph which explains Mr Dhlamini's problem of being unable to connect his house lights so that they can be switched on and off separately.

In PART A of the Activity, learners will draw a circuit diagram of Mr Dhlamini's lights set up. They will then use their micro-electricity kit to set up a model of the circuit diagram that they have sketched. In PART B, learners will solve Mr Dhlamini's problem with the arrangement of his lights. They will design a circuit that will allow the lights to be turned on and off separately. They will draw a circuit diagram to represent their circuit.

They will then use the microelectricity kit to set up a model of the circuit.

This Activity is to explore the learners' existing knowledge of electrical circuits. The things that they need to recall are (a) circuit diagrams; this includes circuit component symbols, and (b) the differences between series and parallel circuits.

PART A

What to discuss

Two examples of acceptable circuits are given on the right.

1. The learners will discuss a whole range of possibilities for why Mr Dhlamini's circuit does not do what he wants. Someone may say the battery is flat or it cannot supply enough current (energy) for the lights to work. The battery can deliver a current for a limited period of time, thereafter it will go "flat" and will need to be recharged. They will raise the issue that he has connected everything in series. So whenever a switch is turned 'on', while the other switches are 'off', the circuit is incomplete and there is no current. Some may suggest that one of the light bulbs is not working; again this causes a break in the circuit.
With the learners working in a group those learners that are a bit rusty will soon remember circuit concepts. Those that are unfamiliar with circuits will quickly learn from the others, as they should feel comfortable enough in the group to ask such questions.
2. A switch will close or open a circuit. When the switch is 'off' the circuit is open and there is no current. When the switch is 'on' the circuit is closed and there is a current. Switches are useful as they help conserve electricity.
3. If the learners understand the concept of a switch they will disconnect any one of the components to break the circuit (open the circuit). Some may ask for extra wire (connecting leads?). If you happen to have some make it available to the learners.
4. If the bulbs are identical they will shine with equal brightness. This means that the current in each light bulb is the same and so should be the same at any point in the circuit. You connect an ammeter in series in the circuit. At any point in the circuit the ammeter reading will be the same.
5. The two bulbs will shine brighter, and again shine equally bright. Encourage your learners to use

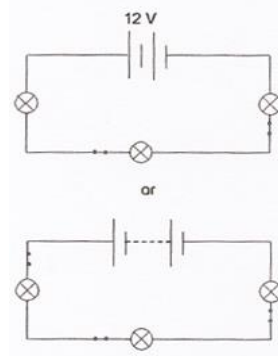

their micro-electricity kits to see the difference. The reasons given for the change will range from there is more current now that there are only two bulbs, to the total resistance of the circuit has decreased so there is an increase in the current, as the voltage (potential difference) across the circuit remains unchanged.

6. At a time which suits the whole class, preferably near the end of the lesson, ask one person from each group to stick their explanations on the classroom wall. The aim of this exercise is for the whole class to come to a consensus about what the terms, 'electricity', 'current' and 'charges' mean. The explanations selected should be written onto a piece of flip chart paper and stuck on a wall and left there till the completion of the electricity unit. Hopefully among the explanations the following facts will arise;
 - 'charge': electrons in a conductor than move when the conductor is part of a closed circuit (or when a potential difference exists across the ends of the conductor); perhaps one group may mention that charges can also be positive or negative ions in a solution;
 - 'current': the flow rate of charges in a conductor; current can be calculated using the formula $I = Q/t$ (this means current is equal to the number of coulombs (charges) that pass a certain point in a conductor in a certain period of time); at this point it would be useful to explain that a coulomb is like a package of electrons/ charges; each coulomb represents $6,25 \times 10^{18}$ electrons.

PART B

What to discuss

1. Mr Dhlamini connected all his lights in series which was why he was unable to control the lights as he wished to. However, he did connect the switches in series with the lights which was a good thing. If his circuit had been connected in parallel he would have been able to switch individual lights on and off. If the switches had been in parallel he would not have been able to do so. The learners should show that the lights of their circuits are connected in parallel with a switch connected in series with each light. Advantages of learners' circuits - individual lights can be turned on and off; the battery will last longer as the three lights in parallel will draw less power than the three lights in series. Two possible circuit diagrams are given.

The diagram shows two circuit configurations. The top circuit has a 12V battery at the top. Three parallel branches connect the battery terminals. The first branch contains a light bulb. The second branch contains a light bulb and a switch in series. The third branch contains a light bulb. Below this is the word 'or'. The bottom circuit also has a 12V battery at the top. Two parallel branches connect the battery terminals. The first branch contains a light bulb and a switch in series. The second branch contains a light bulb. A third branch, containing a light bulb, is connected in parallel with the switch and the top bulb of the first branch.
2. The light bulbs will shine with equal brightness. This means the current divides and equal amounts of charge pass through each light bulb.
3. The bulbs will be of equal brightness. They will be brighter than when there were three bulbs in parallel.
4. The bulb in series would shine much brighter than the two bulbs in parallel. Although the two bulbs in parallel will not be shining brightly, if hardly at all, they will shine with the same brightness. The current that passes through the bulb in series divides and half the charges move through the one parallel bulb and the other half travels through the second parallel bulb. We will do quantitative exercises in later activities.
5. When a battery is put in a closed circuit chemical reactions start. Energy, which comes from the chemical changes, in the form of electric potential energy, is transferred to the electrons of the connecting wires. When the electrons pass through the filament of a bulb they transfer energy to the atoms of the filament. The kinetic energy of the atoms of the filament increases and the it heats up to a high temperature. At this high temperature the filament glows red and then

white and produces light.

6. Current direction is from the positive terminal to the negative terminal of the battery.
7. He could take it down to the local store where they will recharge it. He can put it in a car and have it recharged there. Some students may be quite knowledgeable and suggest attaching the battery to a solar system (photovoltaic cells); some may suggest using a windmill (converting mechanical energy into electrical energy). You are only looking for suggestions of recharging the battery and not the actual procedure.

EXPERIMENT 27 – WHAT IS ELECTRICAL POTENTIAL DIFFERENCE?

CSEC OBJECTIVE (S) : Section D – Objective 3.2

Grade Level – 10

OVERVIEW OF THE ACTIVITY

In this Activity, learners will consolidate their understanding of the concept of electrical potential difference.

PART A

- A voltmeter is a device which measures the difference in electrical potential between two points in a circuit. With a battery, the voltmeter will measure the difference in electrical potential between the positive and negative terminals.
- Electrical potential difference means the difference in electrical potential energy per unit charge between two points.

A voltmeter must be connected across a circuit component. It is also designed to have a high resistance.

This is an example of a simplified sketch to show how the voltmeter measures the difference in potential energy of positive electric charges before and after they have passed through a battery.

When the learners have finished this exercise ask for the flip chart paper to be stuck up on one of the classroom walls.

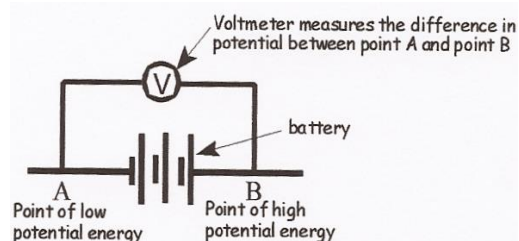

Part B

Allow the learners to take ownership of this activity. If your class is rather large divide it up into two or more groups. Learners learn in different ways, so some learners will learn a tremendous amount from this activity. For others it will consolidate what they already know.

Each “charge person” should receive one “bundle of energy” from each “battery person” The “charge person” moves around the circuit and gives up two “bundles of energy” at the one device and one at the other. The “charge person” then returns to the battery and picks up more energy, and so on.

Things to watch out for:

- that the “charge person” collects the correct “bundles of energy” from each “battery person” on their way through the battery.
- that the “charge people” do not give wrong numbers of “bundles of energy” when passing through the devices.
- any misconceptions that may arise as the learners discuss their role play. Some misconceptions can be that the charges get used up; the battery can have a potential difference which is much greater than 3 volts but can only give out 3 volts because that is what the devices need.
- management issues, such as involvement of all the learners; dominance of the rest of the learners by a group of learners other than the directors; allowing the learners to get too excited or on the other hand the learners are so disinterested they need to be inspired; use of a suitable venue eg, a large room or outside, in an area where other classes are not disturbed. If the learners enjoy the role play, and there is enough time, speak to the director(s) and suggest some changes, and then repeat the role play. You can add another cell or two to the battery or you can change the devices. If your learners repeat the activity

by increasing voltage of the battery, observe how they accommodate for the changes in the transfer of energy. Each of the devices should receive a portion of the extra energy. End off the role play by summarising what your pupils have learned or what has been reinforced.

What to discuss

1. The battery consists of three 1 V cells. The voltage or potential difference of the battery is V. The two devices in the circuit have voltages, potential difference of 1 V and 2 V, respectively. The circuit is closed so there is a current in it. A current is a flow of electric charges, electrons. However, to make it easier we use the term “coulombs” as a unit of charge. As each coulomb passes through the battery it gets 3 joules of energy (1 volt = 3 joules/1 coulomb). The coulomb travels through the circuit and gives energy to each electrical device, 1 joule to the 1 V device and 2 joules to the 2 V device. The coulomb continues moving through the circuit. When it reaches the battery it receives more energy and so on. The battery eventually has no more energy to give to the coulombs that move through it.

2. Volts = joules/coulombs = $J/C = JC^{-1}$

This unit is more meaningful because it shows the two quantities involved, energy and charge, and the relationship between the two. In other words, energy is transferred to each coulomb of charge.

The unit ‘the volt’ is often the reason why students have a problem understanding “potential difference”, in that it does not reflect the relationship between the energy transfer either by a cell to the charges in it, or by moving charges to circuit components.

EXPERIMENT 28 – THE MAXIMUM POTENTIAL ENERGY OUTPUT OF A BATTERY

CSEC OBJECTIVE (S): Section D – Objective 3.2

Grade Level – 10

OVERVIEW OF THE ACTIVITY

In this Activity, learners will use their micro-electricity kits to investigate the emf (maximum potential energy output) of a cell/battery.

6 An example of a set of readings is given in the table below.

circuit component	volts (V)
Battery (not in a circuit)	3
Battery (in a circuit)	2.5
light bulb	2.5

What to discuss

1. The majority of learners will get a reading of 3 V. The cells should be new and unused. Ensure that the learners take accurate voltmeter readings. Make the learners aware of “the error of parallax”. To compensate for this form of error a learner must look straight down onto the voltmeter. The learner’s eye, the voltmeter needle and the scale of the voltmeter must all be in a straight line above each other.
The maximum electrical potential energy output of the battery is 3 joules per coulomb. This means that every coulomb of charge that passes through the cell will get 1.5 joules of energy from each cell.
2. In this discussion the learners should realise that the battery gets hot as it resists the charges that move in it. This resistance is called internal resistance. Part of the emf of the battery is used to move the charges through the battery itself. Some of this energy is transferred to the battery in the form of heat. As soon as the battery heats up, the internal resistance increases and so more energy is used to move the charges and so on.
Once the learners have finished this discussion, inform them about internal resistance. Tell them that internal resistance is a real phenomenon but to make things easier it is ignored. However, they will meet it again when they do complicated circuit problems.
Note: Standard Grade learners are not examined on internal resistance and ‘lost volts’ .
3. The voltmeter’s function is to measure the difference in electrical potential energy of the charges between two points. It must not change the resistance of the component that it is in parallel with. It uses a very little bit of current to work. The rest of the current is in the circuit component.
4. $R_T = r + R_1 + R_2$
5. The voltmeter reading is 3 V, the same as the battery’s emf. It seems as though the voltmeter is connected across the battery only. The light bulb does not glow which means that there is no transfer of energy. This shows that there is no current in the circuit. The reading on the voltmeter also indicates that there is no current in the circuit. If there was a current there would be some “lost volts” because of the resistance offered by the battery. The voltmeter interferes with the working of the circuit and does not allow the light bulb to function.
Some of the learners will give the following incorrect answers and reasons;
 - there will be no reading - because the voltmeter is connected in series and not in parallel

with the light/battery.

- there will be a reading which is less than 3 V because the current is transferring energy to the voltmeter now it is series.
- there will be a reading because the voltmeter is still connected across the terminals of the battery. This reading will be less than that of the battery and of the light bulb because the charges are using a lot of energy to move through the voltmeter.
- the light bulb glows because there is a current in the circuit.
- the light bulb does not glow because all the energy of the moving charges is transferred to the voltmeter.

When the learners test their predictions they will see why it is important to have evidence to support a statement.

TO THINK ABOUT

1. a) "Lost voltage" is the portion of the cell's emf that moves the charges through the cell. In other words, the energy transferred to each coulomb of charge when work is done to move the charge through the cell.
b) The current value is 0 which means that there is no current. The potential difference reading across the cell equals the emf of the cell. There are no "lost volts" due to the internal resistance of the cell because there is no current.
c) As the current increases from zero the potential difference (emf) gets less. The drop in the emf values is due to an increase in "lost volts". The internal resistance of the cell increases as more and more charges move through it. This results in an increase in the energy needed to move the charges, and a drop in the cell's emf, maximum potential energy output.

2. Work done by the moving charges = heat transferred to the hot-plate = 66 000 joules.
Before we can use the equation $V = W/Q$ we need to calculate Q using the equation $Q = It$ (the quantity of charge passing through the hot-plate = number of amperes x number of seconds).

$$\begin{aligned} Q &= It \\ &= 5 \text{ A} \times 60 \text{ s} \\ &= 300 \text{ C} \end{aligned}$$

The number of volts between the terminals of the hot-plate = number of joules/number of coulombs.

$$\begin{aligned} V &= W/Q \\ &= 66\,000 \text{ J}/300 \text{ C} \\ &= 220 \text{ J/C} \\ &= 220 \text{ V} \end{aligned}$$